

clarion

Service Manual

Published by Service Administration Section

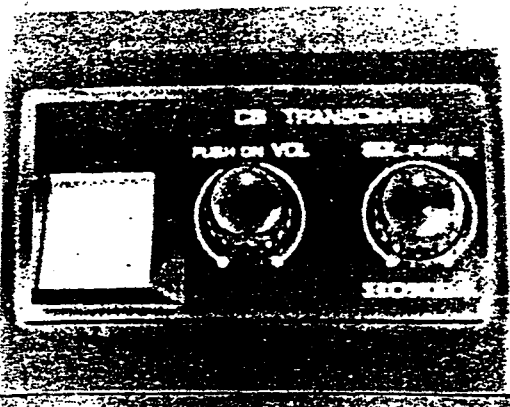

HONDA MOTORCYCLE GENUINE CB TRANSCEIVER Model **JC-213H**

(Genuine NO.08118—MN 500)

Transmitter & Receiver Range :
26.965 ~ 27.405 MHz
Numbers of channels : 40 Ch

Ch	MHz	Ch	MHz	Ch	MHz	Ch	MHz
1	26.965	11	27.085	21	27.215	31	27.315
2	26.975	12	27.105	22	27.225	32	27.325
3	26.985	13	27.115	23	27.235	33	27.335
4	27.005	14	27.125	24	27.245	34	27.345
5	27.015	15	27.135	25	27.255	35	27.355
6	27.025	16	27.155	26	27.265	36	27.365
7	27.035	17	27.165	27	27.275	37	27.375
8	27.055	18	27.175	28	27.285	38	27.385
9	27.065	19	27.185	29	27.295	39	27.395
10	27.075	20	27.205	30	27.305	40	27.405

Antenna impedance : 50 ohms
Power supply voltage : DC13.8V (Negative ground)
Current consumption : Less than 2A

• Receiver

Quieting sensitivity: Better than 6 dB μ
(at 10 dB S/N)
AGC Fom : More than 80 dB
Squelch sensitivity : Threshold, Less than 8 dB μ
Tight, More than 25 dB μ
Selectivity : More than 50 dB
50 dB (at \pm 10kHz detune)

• Transmitter

RF output : 4W max. at 13.8V
Modulation sensitivity : 70 \pm 10%
at 120 mV Mic Input
Frequency tolerance: Less than \pm 0.005%

■ COMPONENTS:

• JC-213H-51

Main Unit		1
Switch	013-3851-00	1
Noise suppressor	085-0280-00	1
Noise suppressor	085-0282-00	1
Noise suppressor	085-0283-00	1
Mounting bracket	300-7461-00	1
• Booklet bag	920-9728-01	1
{ Owner's guide	280-5253-00	1
{ Installation	284-4725-00	1
{ Pamphlet	295-0053-01	1
• Parts bag	921-8460-01	1
{ Hex-bolt	710-5018-30	1
{ Machine screw	714-5055-11	1
{ Machine screw	716-0796-00	2
{ Hex-nut	723-5000-20	1
{ Sems screw	732-6012-11	2
{ Flat washer	740-5000-11	1
{ Installation	284-4828-00	1

REARVIEW AND CONNECTOR:

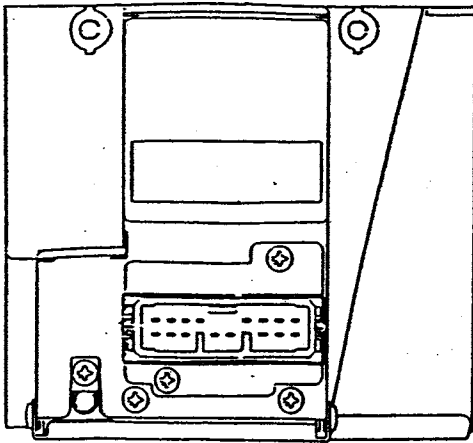

- (3) **Adjusting TX Power**
For setting power, adjust the volume of VR1 so that the power meter indicates about 3.7W.
- (4) **Adjusting Modulation Circuit**
Connect low frequency oscillator to microphone input (MIC-1). Set the oscillator's output to 1KHz, 120mV/600 ohms. Adjust VR2 so that the depth of modulation at this time becomes 70%. If a modulation depth meter is not available, use a synchroscope for the measurement.

$$\frac{1-0.2}{1+0.2} \times 100 = \frac{0.8}{1.2} \times 100 \doteq 70\%$$

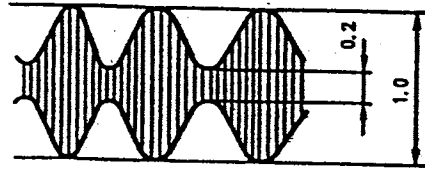

- (5) **Adjusting RX (Receiving Section)**

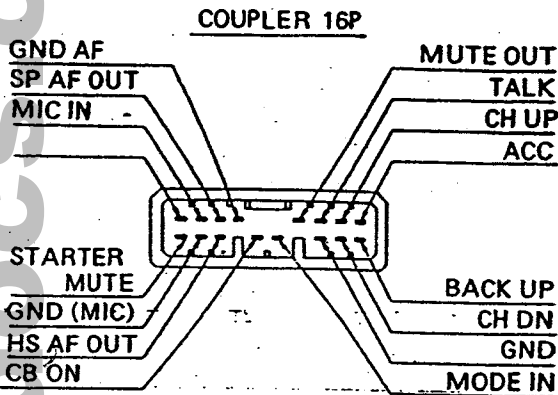

ADJUSTINGS:

- (1) **Adjusting VCO**
Set CB channel to CH1 and connect a DC voltmeter (Does not use circuit tester.) to TP-1. Adjust L10 so that the voltmeter reading becomes $1.9 \pm 0.05V$.
- (2) **Adjusting TX Amp**
Set channel to CH20 and connect power meter to ANT. Adjust T_3, T_2, T_1 and L5 so that the power becomes maximum. (Adjust T_3, T_2, T_1 at least two times.)

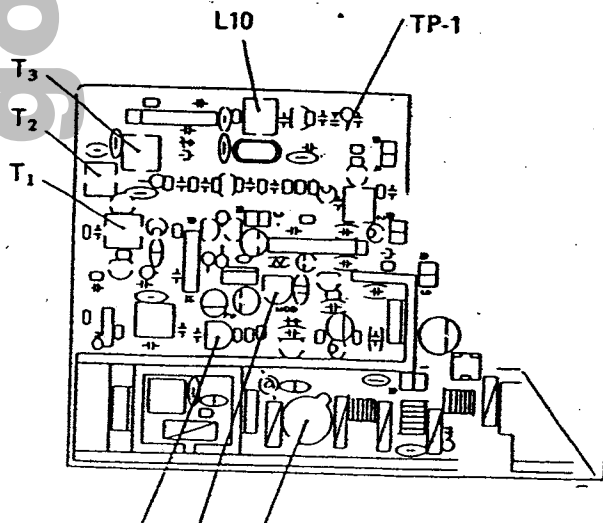
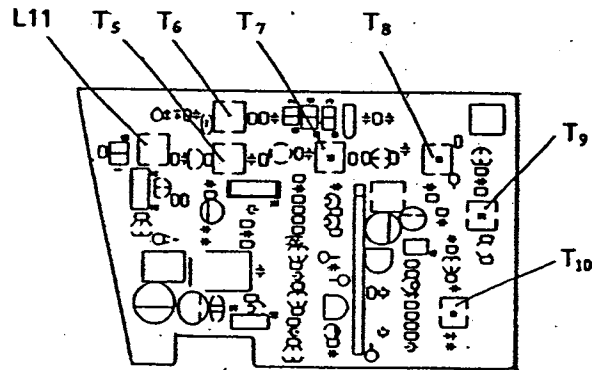

- Set channel to CH 20 (= 27.205 MHz) and connect SSG to ANT (Set SSG to 1 KHZ, 30% MOD). Connect an AC voltmeter (or Synchroscope) to the audio output. Set volume control at half position. Adjust L11, T_5 to T_{10} so that the audio output becomes maximum. Decrease SSG output according to need. (Adjust L11, T_5 to T_{10} at least two times.)

REARVIEW AND CONNECTOR:

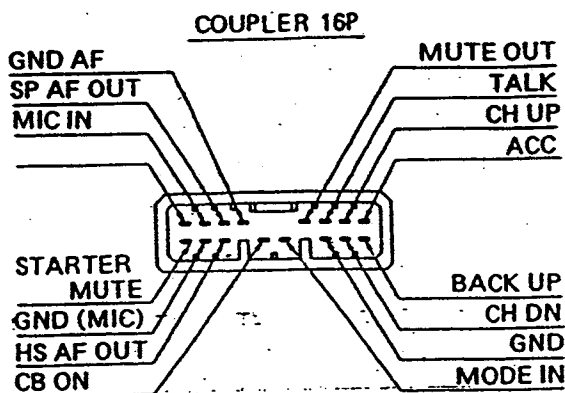
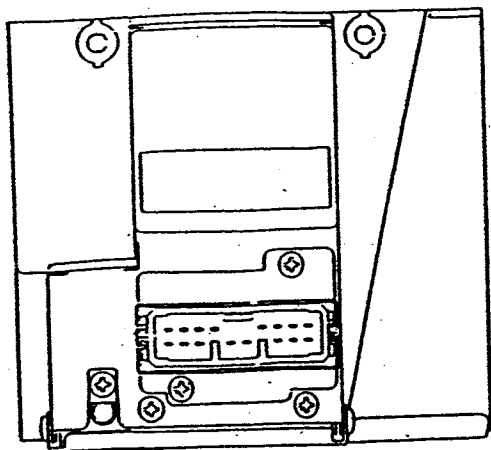

ADJUSTINGS:

- Adjusting VCO**
 Set CB channel to CH1 and connect a DC voltmeter (Does not use circuit tester.) to TP-1. Adjust L10 so that the voltmeter reading becomes $1.9 \pm 0.05V$.
- Adjusting TX Amp**
 Set channel to CH20 and connect power meter to ANT. Adjust T_3, T_2, T_1 and L5 so that the power becomes maximum. (Adjust T_3, T_2, T_1 at least two times.)

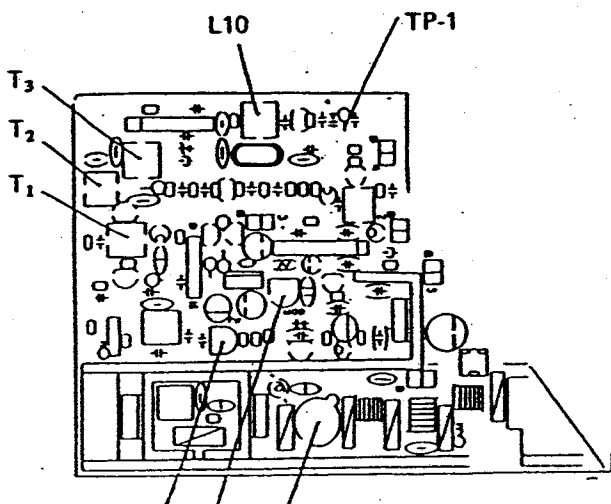

- Adjusting TX Power**
 For setting power, adjust the volume of VR1 so that the power meter indicates about 3.7W.
- Adjusting Modulation Circuit**
 Connect low frequency oscillator to microphone input (MIC-1). Set the oscillator's output to 1KHz, 120mV/600 ohms. Adjust VR2 so that the depth of modulation at this time becomes 70%. If a modulation depth meter is not available, use a synchroscope for the measurement.

$$\frac{1 - 0.2}{1 + 0.2} \times 100 = \frac{0.8}{1.2} \times 100 \approx 70\%$$

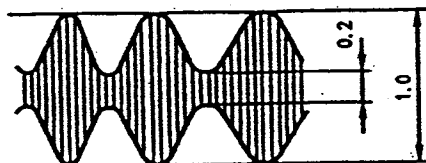

- Adjusting RX (Receiving Section)**

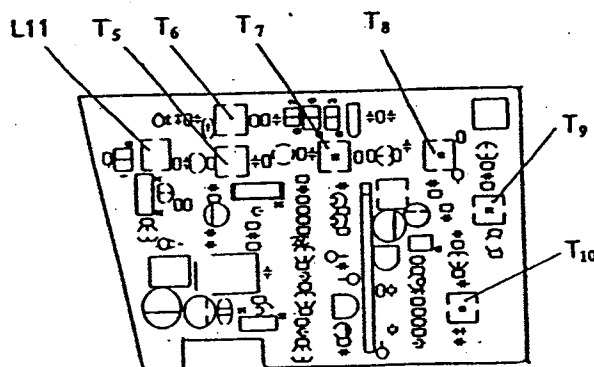

Set channel to CH 20 (= 27.205 MHz) and connect SSG to ANT (Set SSG to 1 KHZ, 30% MOD). Connect an AC voltmeter (or Synchroscope) to the audio output. Set volume control at half position. Adjust L11, T_5 to T_{10} so that the audio output becomes maximum. Decrease SSG output according to need. (Adjust L11, T_5 to T_{10} at least two times.)

CONNECTION FOR ADJUSTMENT:

RX SECTION

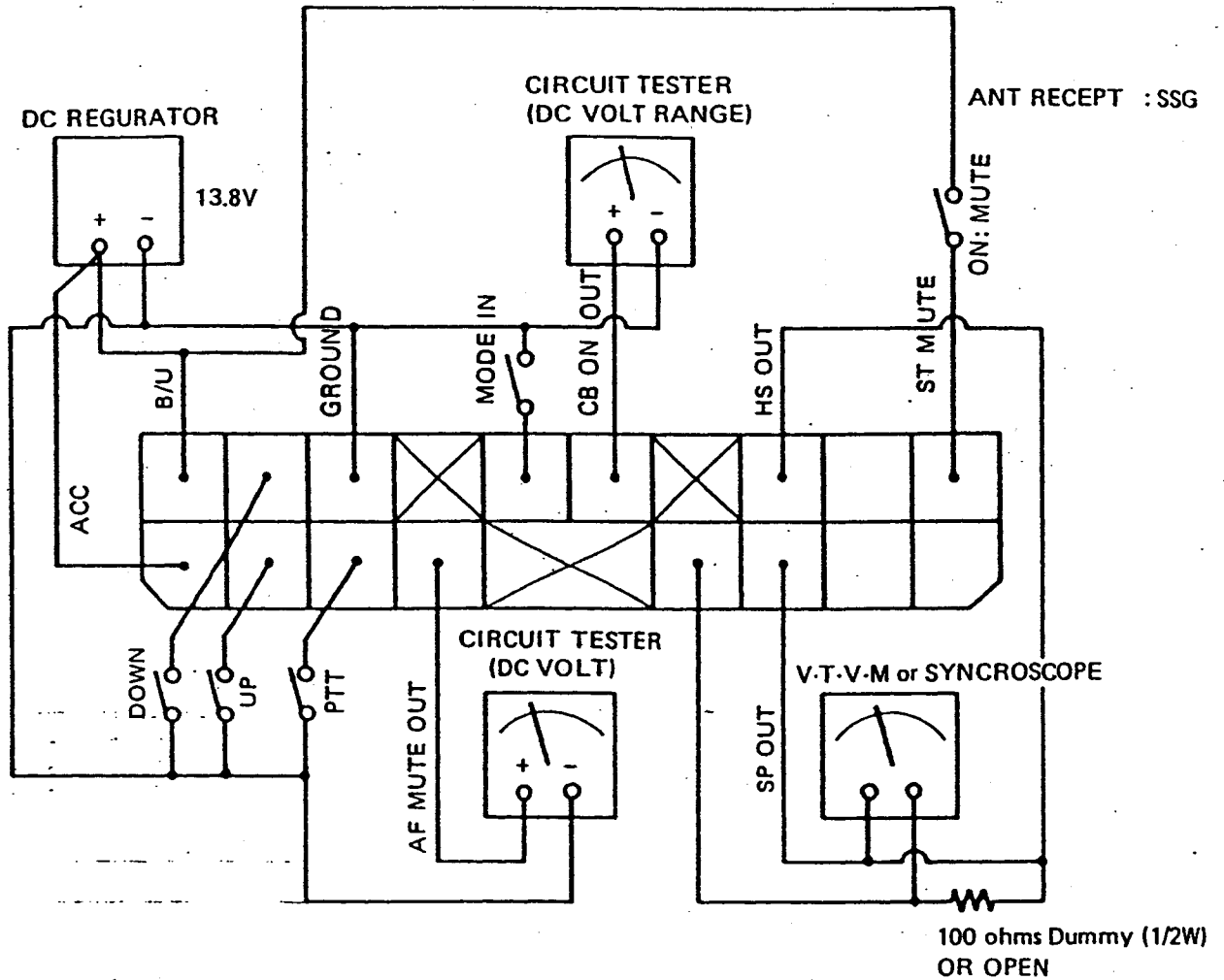

[RADIO/CASSETTE I/O]

CB ON OUT FOR POWER AMP TO ON	CB POWER OFF	0V
	CB POWER ON	±13.8V

AF MUTE OUT FOR RADIO/CAS	TX MODE	—		±13.8V	
	RX MODE	SQ CLOSED	—		0V
		SQ OPEN OR	CB HS MODE SELECT	RADIO HS MODE	±13.8V
				RADIO SP MODE	0V
RECEIV- ING	CB SP MODE SELECT	RADIO HS MODE	0V		
		RADIO SP MODE	±13.8V		

COMMENT: SQ CLOSED = RX INDICATOR OFF
 SQ OPEN = RX INDICATOR ON
 RADIO HS MODE = SAME MODE IN OPEN
 RADIO SP MODE = SAME MODE IN SHORT (GROUND)

goldwingdocs.com

• TX SECTION

goldwingdocs.com

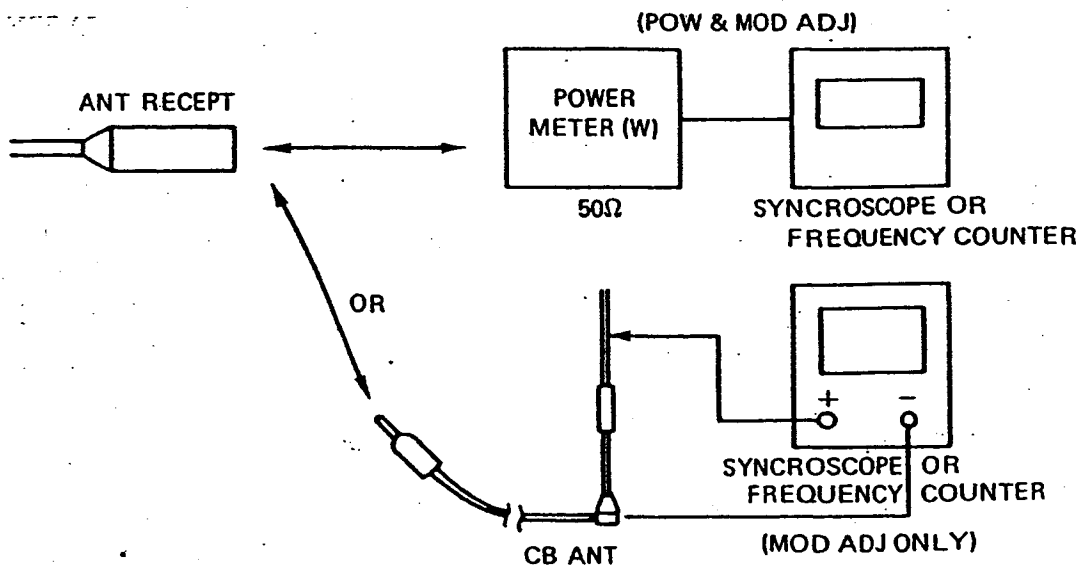
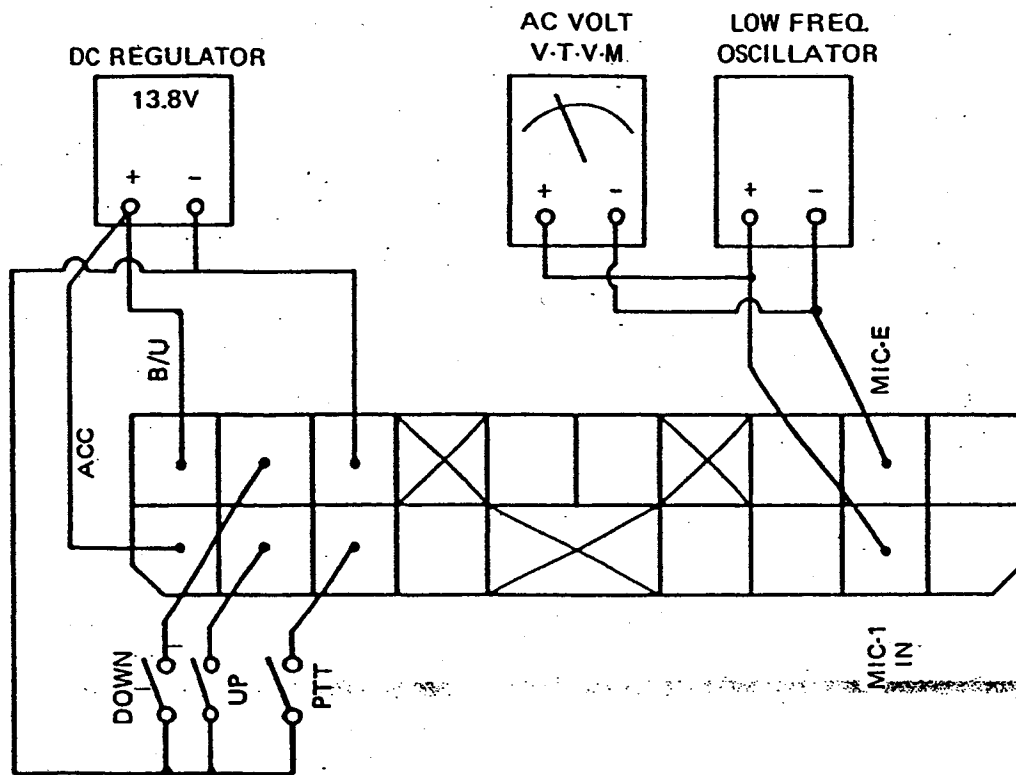

BLOCK DIAGRAM

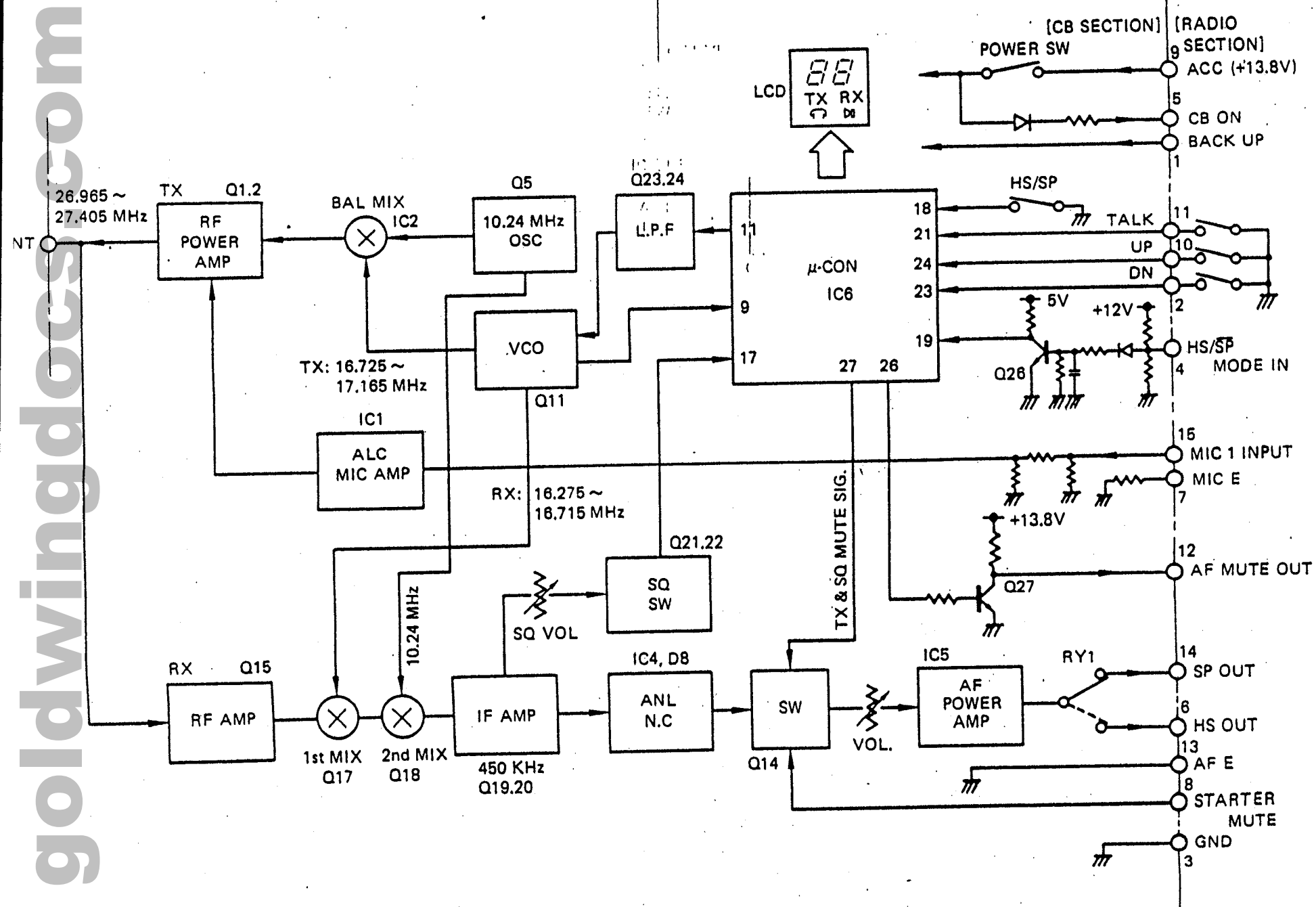

goldwingd.com

EXPLANATION OF IC's:

Refer to description in IC service manual vol 2.

TA78008AP 051-0624-00 3 Terminal Regulator P50

μPC575C2 051-0303-00 Audio power amp.

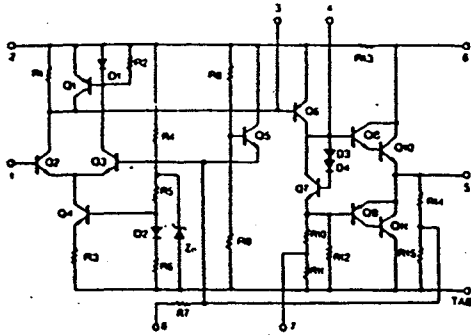
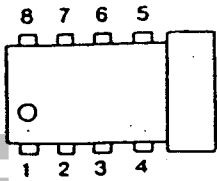

μPC1037HA 051-0988-00 Bipolar Analog Integrated Circuit

Outline

The μPC1037H is a double balanced modulation circuit. It is most suitable for SSB modulation/demodulation. Because of its one- $\epsilon\pi$ configuration the circuit is well-balanced and has good thermal stability. The μPC1037H is highly advantageous for packaging, needing a few attaching parts and using 7 pin Single In-line Package.

Outward Form

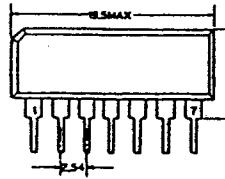

Connection Diagram

Terminal No.	Pin connection
1	Vcc
2	OUTPUT 1
3	OUTPUT 2
4	GND
5	SIGNAL INPUT
6	BYPASS
7	CARRIER INPUT

Features

- o Less carrier and signal leaks.
- o Less intermodulation distortion.
- o Smaller carrier level required.
- o No adjustments necessary because of fewer attaching parts.

Absolute Maximum Ratings ($T_a = 25^\circ\text{C}$)

Supply voltage	V_{cc}	9.0V
Power dissipation	P_o	270mW*
		* $T_a = 75^\circ\text{C}$

μPC1170H 051-0254-00 Pre Amplifier with ALC

Outward Form

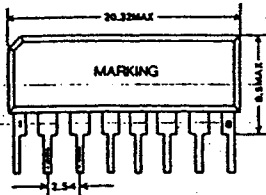

Absolute Maximum Ratings

Item	Symbol	Rating	Unit
Supply voltage 1	V_{cc1}	12.0	V
Supply voltage 2	V_{cc2}	18.0	V
Power dissipation	P_o	270	mW

Test Circuit

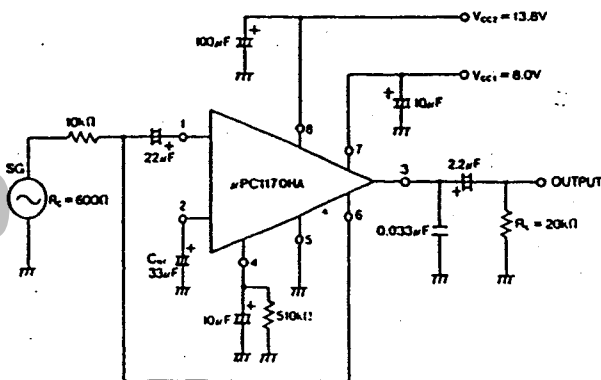

μPD1720G-528-00 051-1009-00 AM Tuner Controller

Outward Form

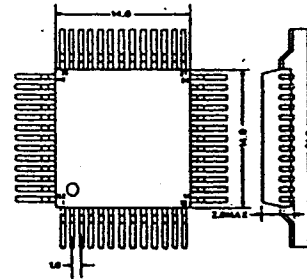

Outline

The μPD1720G-528 is an IC developed for CB car radios. Sending and receiving status of this IC is switched by toggle switch. The sending is made by N value in which 450kHz was added to the N value of the channel in receiving mode. The channels are changed with the UP/DOWN momentary key. The radio will hold the channel 9 when the emergency key is pressed. Channel changing is not possible during this mode. The emergency key has alternate switching function. When it is pressed again the function returns to the previously activated channel. The channels range from ch 1 to ch 40. The channels can only be changed during receiving mode.

Features

- (1) 4 bit microprocessor for digital tuning.
- (2) PLL and LCD driver installed.
- (3) $5V \pm 10\%$ single power supply.
- (4) Send/receive function by press-to-talk key.
- (5) Manual tuning.
- (6) Forced holding of the channel 9 by emergency key.
- (7) Last channel memory.
- (8) Headphone system/speaker.
- (9) LCD display.

PARTS LIST:

REF NO.	PART NO.	DESCRIPTION	Q'TY	REF NO.	PART NO.	DESCRIPTION	Q'TY
D 3	001-0160-10	DIODE (15V 166S)	1	C 3	144-1212-10	MICA-CAPACITOR (120PF)	1
1, 5, 6, 7, 9, 10, 11, 12, 14, 16, 18, 19	001-0330-00	DIODE (1SS 119)	12	C 13	144-1812-10	MICA-CAPACITOR (180PF)	1
D 4, 17,	001-0360-00	DIODE (S 5566B)	2	C 6, 8	144-2712-10	MICA-CAPACITOR (270PF)	2
D 8	001-0361-00	DIODE (1SS 198)	1	C 4	144-3312-10	MICA-CAPACITOR (330PF)	1
	001-0421-18	DIODE (MTZ 5.1J)		C 7, 11	144-4712-10	MICA-CAPACITOR (470PF)	2
D 15	(001-0423-18)	DIODE (MA 4051)	1	C 116	160-1012-05	CERAMIC-CAPACITOR (100PF B)	1
	(001-0425-18)	DIODE (HZS 5.1E)		60, 61, 62, 67, C 71, 84, 94, 95, 98, 101, 102	160-1022-05	CERAMIC-CAPACITOR (1000PF)	11
D 2	001-0421-20	DIODE (MTZ 6.2J)	1	C 8, 15	160-1512-05	CERAMIC-CAPACITOR (150PF B)	2
TH 1	002-0186-00	THERMISTOR	1	C 24	160-1812-05	CERAMIC-CAPACITOR (180PF B)	1
TH 2	002-0190-00	THERMISTOR	1	C 10	160-8212-05	CERAMIC-CAPACITOR (820PF B)	1
T 8	005-0750-00	IF-TRANS FORMER	1	14, 18, 18, 22, C 31, 40, 48, 49, 68, 72, 74, 81, 87, 89	171-1032-06	CERAMIC-CAPACITOR 0.01 μ F SR	14
T 9	005-0752-00	IF-TRANS FORMER	1	C 90	171-1042-06	CERAMIC-CAPACITOR 0.1 μ F SR	1
T 10	005-0753-00	IF-TRANS FORMER	1	C 66, 107,	171-1532-06	CERAMIC-CAPACITOR 0.015 μ F SR	2
T 7	005-0761-00	IF-TRANS FORMER	1	C 42, 43, 47, 75, 76, 78, 79, 81	171-2232-06	CERAMIC-CAPACITOR 0.022 μ F SR	8
T 4	005-0809-00	IF-TRANS FORMER	1	C 114	171-2732-06	CERAMIC-CAPACITOR 0.027 μ F SR	1
CF 2	005-0854-01	IF-TRANS FORMER	1	C 54	171-3322-06	CERAMIC-CAPACITOR 0.0033 μ F SR	1
T 1, 2, 3, 5, 6	005-0922-00	IF-TRANS FORMER	5	C 12, 60, 80, 83, 108, 109, 111,	171-4732-06	CERAMIC-CAPACITOR 0.047 μ F SR	7
CF 1	005-0967-00	IF-TRANS FORMER	1	C 63	172-2242-20	POLYESTER-CAPACITOR 0.22 μ F	1
CH 1	009-0603-00	CHOKE	1	C 28, 119	173-1022-10	POLYESTER-CAPACITOR 0.001 μ F	2
L 5	010-1792-00	COIL	1	C 36	173-3332-10	POLYESTER-CAPACITOR 0.033 μ F	1
L 11	010-2039-00	COIL	1	C 37	173-4722-10	POLYESTER-CAPACITOR 0.0047 μ F	1
L 1	010-2046-07	COIL	1	C 1, 28, 30	173-4732-10	POLYESTER-CAPACITOR 0.047 μ F	3
L 7	010-2046-24	COIL	1	C 20	174-1000-13	CERAMIC-CAPACITOR 10PF CH	1
L 9	010-2052-00	COIL	1	C 21, 45	174-1017-13	CERAMIC-CAPACITOR 100PF CH	2
L 10	010-2156-00	COIL	1	C 41	174-1090-13	CERAMIC-CAPACITOR 1PF CH	1
L 8	010-2157-00	COIL	1	C 73	174-1507-13	CERAMIC-CAPACITOR 15PF CH	1
L 13	010-2158-00	COIL	1	C 70	174-2090-13	CERAMIC-CAPACITOR 2PF CH	1
L 2, 3, 4	010-2159-00	COIL	3	C 103, 118	174-2200-13	CERAMIC-CAPACITOR 22PF CH	2
L 6	010-2160-00	COIL	1	C 82, 93	174-2207-13	CERAMIC-CAPACITOR 22PF CH	2
VR 1	012-3808-05	VARIABLE-RESISTOR (4.7K Ω)	1	C 25	174-2700-13	CERAMIC-CAPACITOR 27PF CH	1
VR 2	012-3808-06	VARIABLE-RESISTOR (10K Ω)	1	C 18, 46	174-3090-13	CERAMIC-CAPACITOR 3PF CH	2
VR 4	012-3808-08	VARIABLE-RESISTOR (33K Ω)	1	C 77	174-3307-13	CERAMIC-CAPACITOR (33PF CH)	1
VR 3	012-3808-10	VARIABLE-RESISTOR (100K Ω)	1	C 60	174-3907-13	CERAMIC-CAPACITOR (39PF CH)	1
RY 1	014-0519-00	RELAY	1	C 5, 17	174-4700-13	CERAMIC-CAPACITOR (47PF CH)	2
IC 4	051-0190-00	IC (CZ 2)	1	C 44	174-4707-57	CERAMIC-CAPACITOR (47PF UR)	1
IC 1	051-0254-00	IC (μ PC 1170H)	1	C 23	174-5607-13	CERAMIC-CAPACITOR (56PF CH)	1
IC 5	051-0303-00	IC (μ PC 575C 2)	1	C 2	174-7090-13	CERAMIC-CAPACITOR (7PF CH)	1
IC 3	051-0624-00	IC (TA 78008AP)	1	C 34, 53, 110	042-0176-00	ELECTROLYTIC-CAPACITOR (16V 10 μ F TAN)	3
IC 2	051-0968-00	IC (μ PC 1037HA)	1	C 82	042-0199-01	ELECTROLYTIC-CAPACITOR (10V 22 μ F TAN)	1
IC 6	051-1009-00	IC (μ PD 1720G-528-00)	1	C 38	042-0200-00	ELECTROLYTIC-CAPACITOR (10V 47 μ F TAN)	1
X 2	061-1054-00	CRYSTAL (4.5MHZ)	1	C 27	042-0226-00	ELECTROLYTIC-CAPACITOR (35V 0.1 μ F TAN)	1
X 1	061-1070-00	CRYSTAL (10.24MHZ)	1	C 68, 87	042-0227-00	ELECTROLYTIC-CAPACITOR (16V 2.2 μ F TAN)	2
Q 6	100-0473-25	TRANSISTOR (2SA 473Y)	1	C 85	042-0230-00	ELECTROLYTIC-CAPACITOR (35V 0.47 μ F TAN)	1
Q 7	100-0817-15	TRANSISTOR (2SA 817-O)	1	C 113	179-1073-32	ELECTROLYTIC-CAPACITOR (16V 100 μ F)	1
Q 9	100-1048-00	TRANSISTOR (2SA 1048-O, Y, GR)	1	C 98	179-1083-13	ELECTROLYTIC-CAPACITOR (6.3V 1000 μ F)	1
Q 1	102-1945-00	TRANSISTOR (2SC 1945)	1	C 100	179-1083-33	ELECTROLYTIC-CAPACITOR (16V 1000 μ F)	1
Q 8	102-1959-25	TRANSISTOR (2SC 1959Y)	1	C 29, 32, 86, 104, 115	179-2273-23	ELECTROLYTIC-CAPACITOR (10V 220 μ F)	5
Q 3	102-2086-00	TRANSISTOR (2SC 2086)	1	C 62, 112	179-3373-33	ELECTROLYTIC-CAPACITOR (16V 330 μ F)	2
Q 2	102-2166-00	TRANSISTOR (2SC 2166)	1	C 64	179-4773-23	ELECTROLYTIC-CAPACITOR (10V 470 μ F)	1
10, 13, 16, 21, 22, 25, 26, 27	102-2458-00	TRANSISTOR (2SC 2458-Y, GR, BL)	8	C 65	179-4773-33	ELECTROLYTIC-CAPACITOR (16V 470 μ F)	1
Q 4, 5, 12, 18, 19, 20	102-2668-25	TRANSISTOR (2SC 2668Y)		C 38, 55, 57, 58	182-1053-09	ELECTROLYTIC-CAPACITOR (50V 1 μ F)	4
	(102-2668-15)	TRANSISTOR (2SC 2668O)	6	C 39, 55, 88	182-1063-32	ELECTROLYTIC-CAPACITOR (16V 10 μ F)	3
	(102-2786-12)	TRANSISTOR (2SC 2786LF)		C 105	182-2253-62	ELECTROLYTIC-CAPACITOR (50V 2.2 μ F)	1
Q 24	102-2785-60	TRANSISTOR (2SC 2785-HPEK)	1	C 33	182-2253-63	ELECTROLYTIC-CAPACITOR (50V 2.2 μ F)	1
Q 14	103-1504-00	TRANSISTOR (2SD 1504-D, E)	1	C 89	182-4756-32	ELECTROLYTIC-CAPACITOR (16V 4.7 μ F NP)	1
Q 11, 15	108-0193-12	TRANSISTOR (2SK 193LF)	2	C 106	182-4763-32	ELECTROLYTIC-CAPACITOR (16V 47 μ F)	1
Q 23	108-0363-00	TRANSISTOR (2SK 363GRBLV)	1				
Q 17	124-0859-28	TRANSISTOR (3SK 59NEW-GR)	1				
R 38	111-3701-81	FILM-R (1/2 W 33 Ω)	1				

goldwingdocs.com

Pin No.	Symbol	Terminal name	Function
15	XI	XTAL	Connection terminal for crystal oscillator. Allows connection of 4.5MHz crystal. Adjust the oscillation frequency by observing XO terminal.
16	XO		
17	PA3	Port A	4 bit I/O (Input/Output) port. Input and output can be specified bit by bit with this port. This is done with the contents of address 5FH in the data memory (RAM) called PA I/O WORD. Input port to output to SQ OUT and AF MUTE 1. Input port to switch H/S OUT (PB3). Input port to output to AF MUTE 1. Outputs HIGH LEVEL while the PLL is locked during sending mode. Outputs LOW LEVEL during unlocked and receiving modes.
18	PA2		
19	PA1		
20	PA0		
21	K3	KEY RETURN SIGNAL INPUT	4 bit input ports. Usually used as input of the key matrix. When KIN command is executed, the status of this terminal is read into the data memory (RAM) specified at the respective operand part. The upper 2 bits of port B and port C (PC3 and PC2) are especially used as a signal source for key return, usable constitution.
24	K0		
		Port B	4 bit output port. Because of the smaller sink power supply, this port is used as a key return signal source of the key matrix. In other words, by using this port as a key return signal source the external diode can be omitted. Note: When this port is used as a normal output port, LOW LEVEL might not be output properly in some circuits to be driven due to the small sink power supply. In that case, connect the pull-down resistor.
25	PB3	H/S OUT	Output by HS/SP key input (PA2) with alternate switching. LCD "SP" is displayed during HIGH LEVEL output, and LCD "HS" is displayed during LOW LEVEL output.
26	PB2	AF MUTE1	MUTE output port. The MUTE signal is output in each port status of P.TALK (K3), SQ OUT (PB1), H/S OUT (PB3) and MODE IN (PA1).
27	PB1	SQ OUT	Outputs LOW LEVEL when the SQ IN (PA3) input is in LOW LEVEL. Outputs HIGH LEVEL when the SQ IN input is in HIGH LEVEL and when the P.TALK key (K3) is in LOW LEVEL.
28	PB0	AF MUTE2	MUTE output port. Upon power supply startup and when the CHIP ENABLE rises from LOW to HIGH, the MUTE signal is output for approx. 50 msec. after startup, and the PLL signal is output (approx. 450 msec. in total) in order to suppress the noise. When the PLL signal is output, the MUTE is output for approx. 50 msec. before and approx. 375 msec. after PLL output (approx. 70 msec. in total). When the H/S OUT output is switched over, the MUTE signal is likewise output for approx. 50 msec. before and approx. 375 msec. after the PLL output (approx. 70 msec. in total). MUTE is output during UP/DOWN fast forward.

Key Matrix
Key Matrix Connection Table

K3	K2	K1	K0
P.TALK	CH-9	DOWN	UP

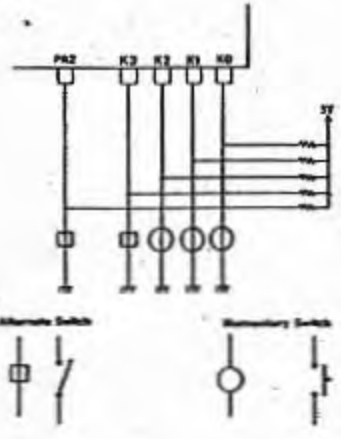
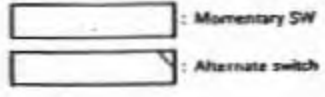
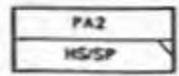

Alternate Switch

Symbol	Function
P.TALK	Sending/receiving switch-over. Switches to sending mode during LOW LEVEL. As channel change cannot be made during this mode, the sending is made with the channel which was operated before switch-over. The N value (in which 5 AH was added during receiving mode of the channel) is output and switched to sending mode. When the PLL is locked after the N value was output, TX is displayed. During the sending mode, other keys than P.TALK key are not accepted except HS/SP key. When the LEVEL is switched from LOW to HIGH, the mode switches to receiving. The N value, from which 5 AH was subtracted, returns to original value of the channel during receiving. Channels can be changed during receiving mode. When SQ OUT is in HIGH LEVEL during receiving mode, RX is displayed.
HS/SP	The HS/SP key changes output to H/S OUT (PB3) in order to switch over the headphone system and speaker. When the H/S key (PA2) is in HIGH LEVEL, HIGH LEVEL is output from the HS OUT (PB3) and switches to SP mode. When the HS/SP key is in LOW LEVEL, LOW LEVEL is output from the HS OUT and switches to HS mode.

Momentary SW

Symbol	Function
CH-9	This emergency key will hold the emergency channel 9. The channel changing is not possible during this mode. When the key is pressed again, it returns to the previously activated channel. This key is not accepted during sending mode.
UP/DOWN	Channel UP/DOWN key. Each time the key is pressed the channels are moved up (UP key ON) or down (DOWN key ON) one at a time. When the key is held down for longer than 1 second, the channels move rapidly at a rate of approx. 8 channels/sec. When the UP key is pressed at the highest channel frequency, the upward channel seek continues at the lowest frequency. When the DOWN key is pressed at the lowest channel frequency, the downward channel seek continues at the highest frequency and the saw-tooth-wave tuning is made. In this mode, the last key pressed has the priority. However, this is not accepted when two keys are pressed simultaneously. When the P.TALK switches from HIGH to LOW LEVEL during fast channel seek, the UP/DOWN stops immediately. When the emergency key is pressed during fast channel seek, the channel at that time is saved and channel 9 is held.