

TOOLS REQUIRED

- Ratchet and 12" extension
- 7 and 10 mm Sockets
- 8, 10, and 14 mm Box wrenches
- Electric drill
- 1/8", 7/32", 3/16", and 1/4" Bits
- 4 mm Allen wrench
- #1 and #2 Phillips screwdrivers
- Hammer
- Centerpunch
- Masking tape

PARTS LIST

for Radio—H/C 096524 P/N 08118-46306

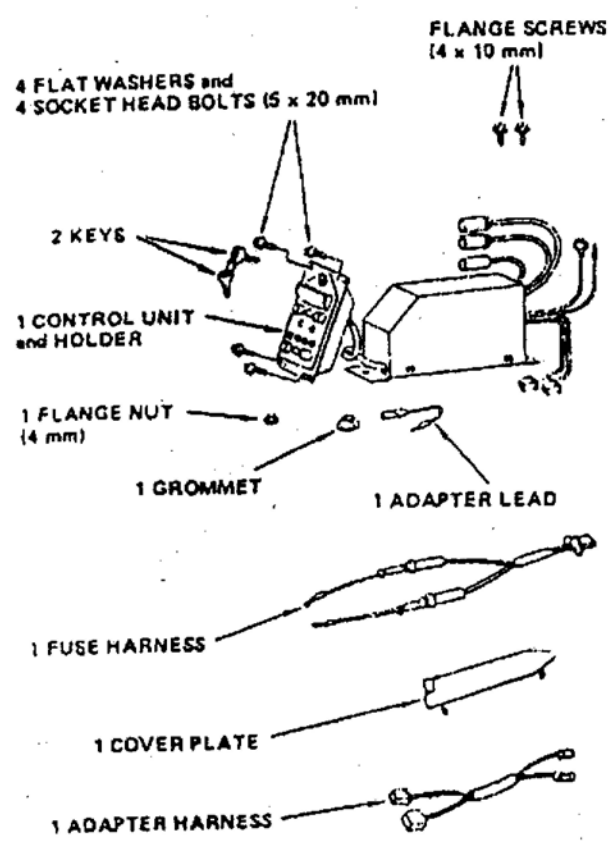

1 OWNER'S GUIDE

for Power booster—H/C 094138, P/N 08118-46321

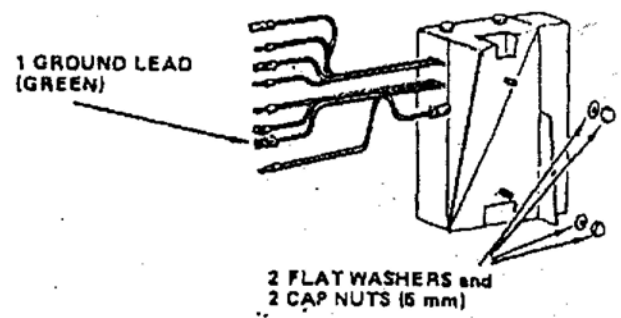

for Speakers—H/C 091608, P/N 08118-46330

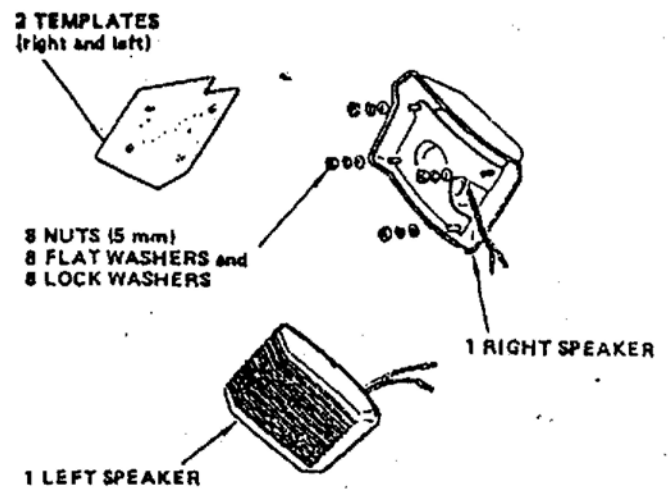

for Antenna—H/C 096668, P/N 08118-46345

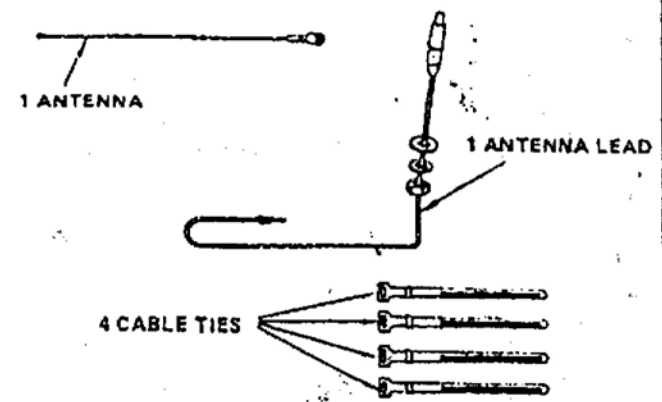

for Antenna mount—H/C 096526, P/N 08118-46343
 (see pages 8 and 9) H/C 096395, P/N 08118-46342
 H/C 101992, P/N 08118-MA440

goldwingdocs.com

RADIO COMPONENT LOCATIONS

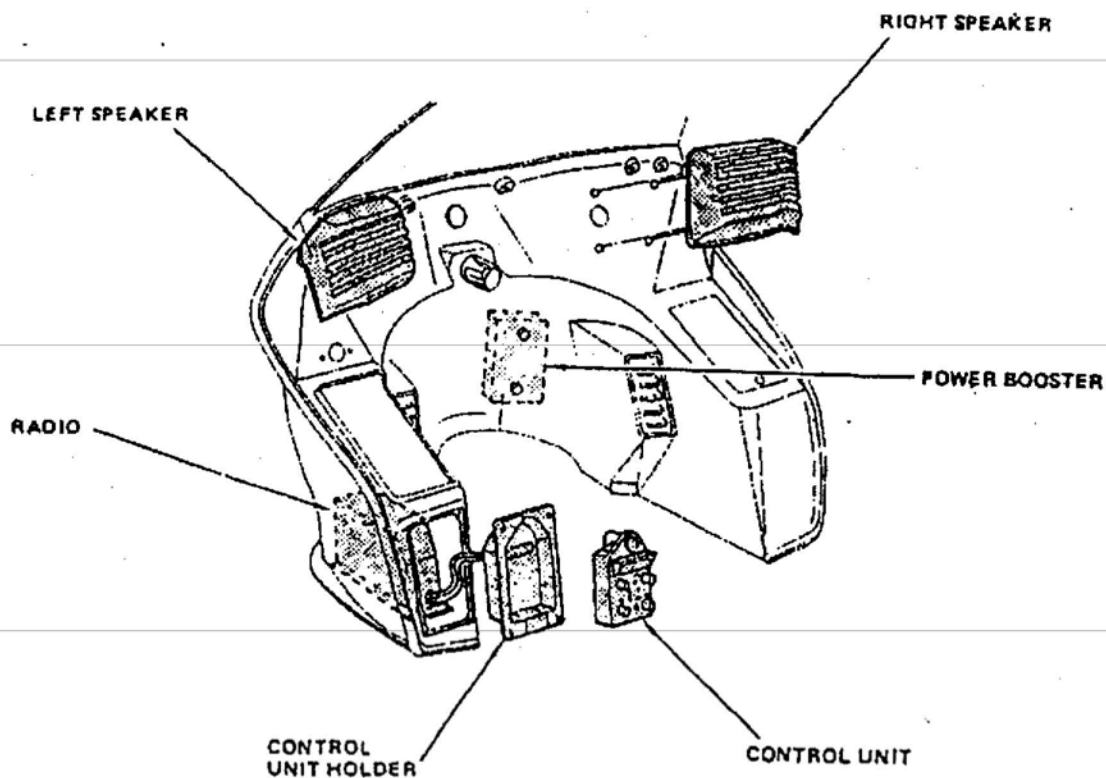

PREPARATION

1. Remove the left and right lower fairing panels.

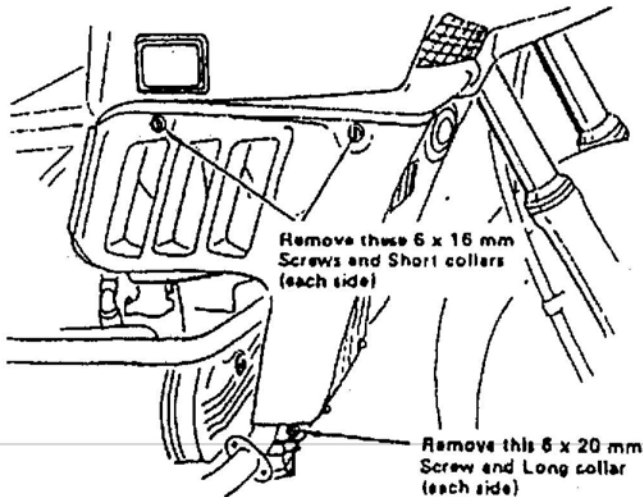

2. Unplug the 9-pin connector from the fairing receptacle.

3. Remove the four cap nuts from the front of the fairing.

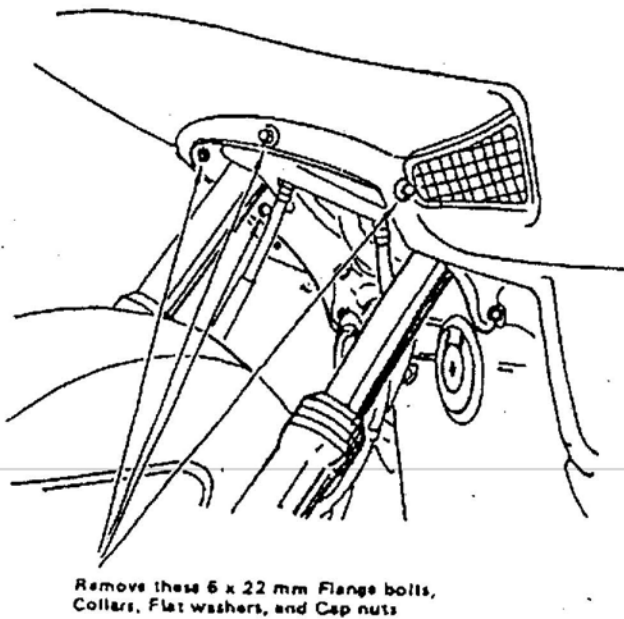

4. Remove the four deep cap nuts (two on each side) from the rear of the fairing, then remove the fairing.

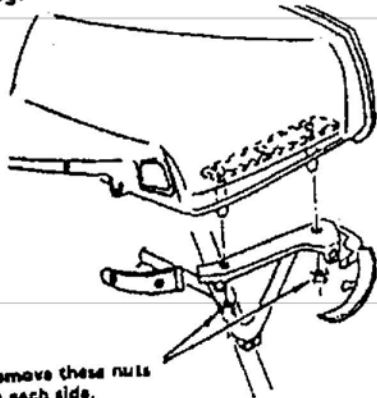

5. Remove both front turn signals.
6. Remove both fairing pockets and the hole cover from the left side.

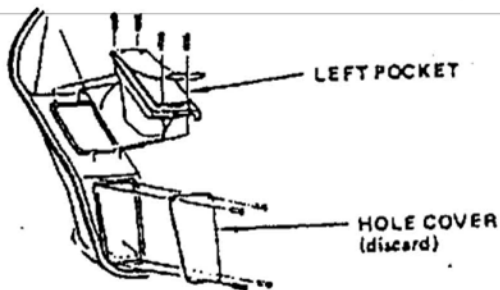

7. Install the windshield if not installed. (Windshield must be installed before speakers.)

NOTE: On some models, the rear view mirrors mount on the handlebars.

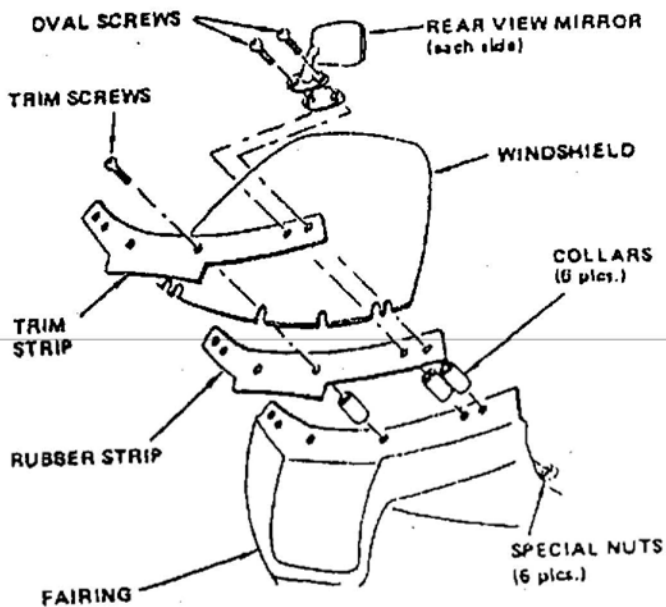

8. Remove the two 18 mm rubber plugs from the fairing at the speaker locations.
9. Tear the template into two pieces along the perforated line, then fold each piece along its guide line. Tape the templates in place with their top and outside edges aligned with the fairing where shown by the arrows. (Bend both pieces slightly so they will fit the contour of the fairing.)

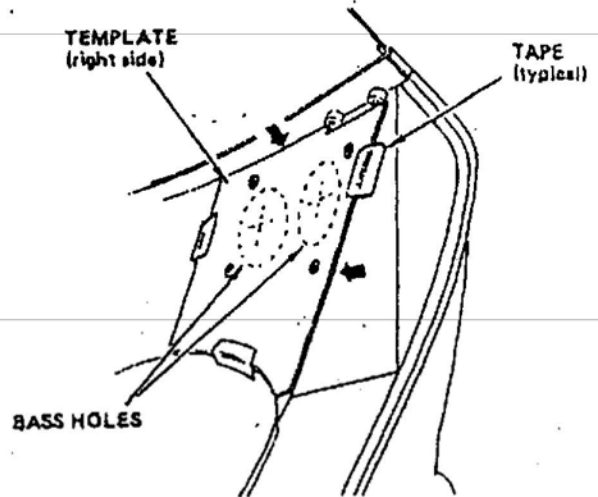

10. Mark the four hole locations through the template, and drill 1/8" pilot holes. Then carefully drill 1/4" holes through the pilot holes.

NOTES:

- Use a sharp bit and extreme care as the bit will tend to wander in the plastic.
- For a better balanced response with a richer, deeper bass, drill two holes in the fairing where shown on the template. Drill correct size pilot holes first, then cut the large holes with a 2" hole saw and pilot.

11. Mark and drill two holes for the power booster studs through the recesses in the fairing. Drill on 3-5/16" centers with a 7/32" bit.

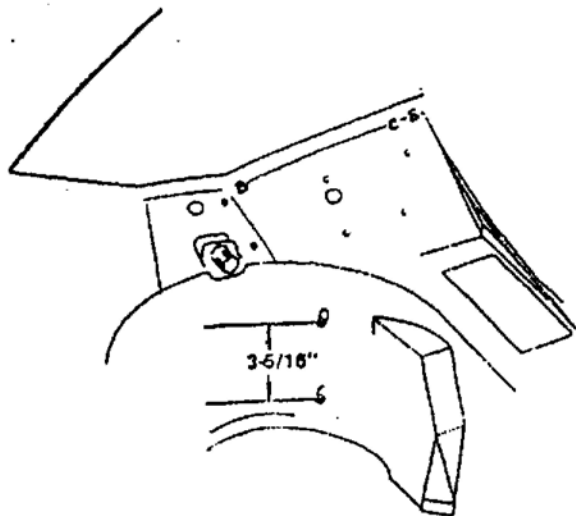

12. If the accessory gauges are going to be installed, go on with this step and step 13. If not, go on to Power Booster Installation. Position the base plate for the accessory gauge panel on the fairing as shown.

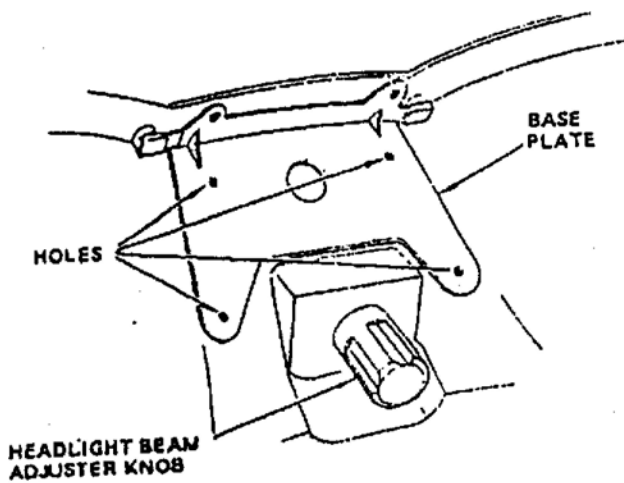

13. Align the four 5 mm holes in the plate with the existing punch marks on the fairing, then drill four holes through the plate and fairing, with a 3/16" bit.

NOTE: Installation instructions for the accessory gauge panel are furnished with the panel.

POWER BOOSTER INSTALLATION

1. Untie the power booster wires, then insert the booster into the fairing through the right turn signal hole, fit its studs through the drilled holes, and put a flat washer and 5 mm cap nut on each stud. Tighten the nuts securely.

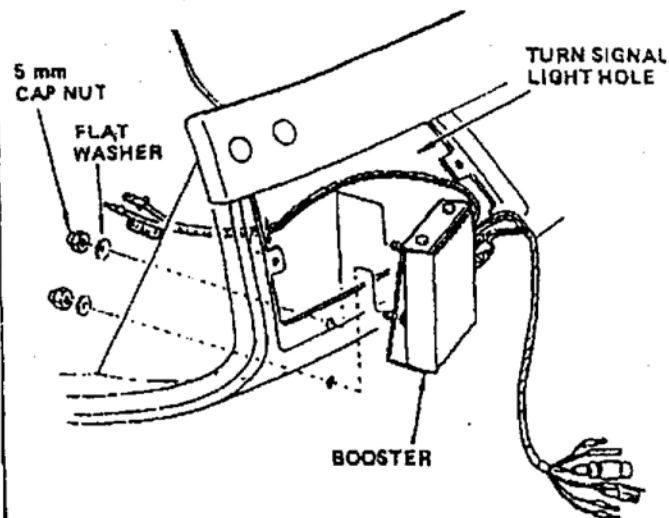

2. Route the booster speaker wires (white for left and grey for right) through the applicable speaker holes. Route the left speaker and radio wires under the headlight.

SPEAKERS

1. Connect the speaker wires to the booster wires.

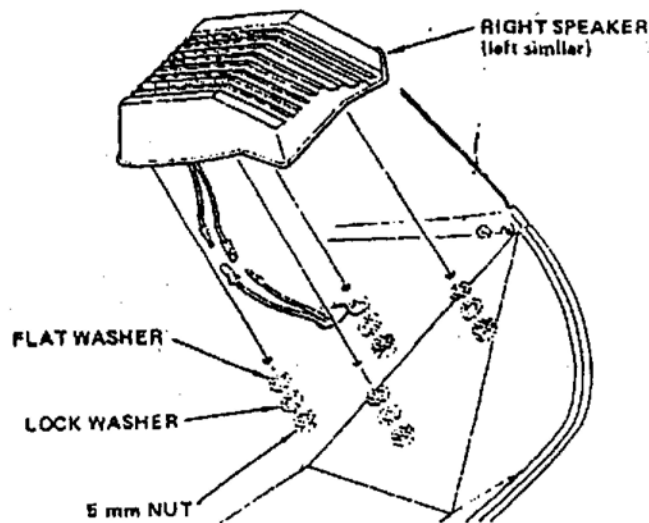

2. Then fit the speaker studs through the holes drilled in the fairing, and put a 5 mm flat washer, lock washer, and nut on each stud. Tighten the nuts securely and be sure the speaker wires are not pinched.

RADIO INSTALLATION

1. Start two 4 x 10 mm flange screws into the holes in the nutplate, through the terminal(s) of the green ground wire(s) shown.

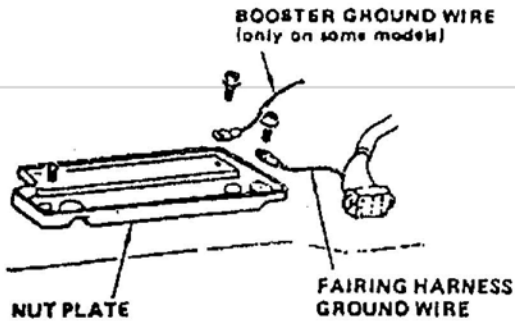

2. Connect the green ground wire from the power booster to the ground terminal on the front of the radio.
3. Remove the plastic plug from the connector holder, feed the antenna wire through the hole, then install the rubber grommet.

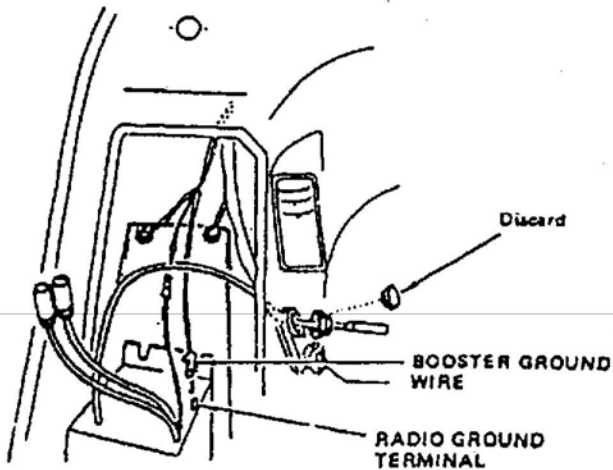

4. Slip the slots in the base of the radio under the ground terminals on the nutplate, then set the radio down so the hole in the rear of the base fits over the stud on the nutplate.

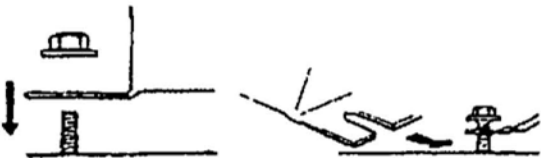

5. Secure the radio with a 4 mm flange nut on the stud. Tighten the nut and the two screws securely.

6. Install the control unit holder in the fairing.

CAUTION: Be sure the wires are not pinched or twisted. Do not pull on the wires with excessive force.

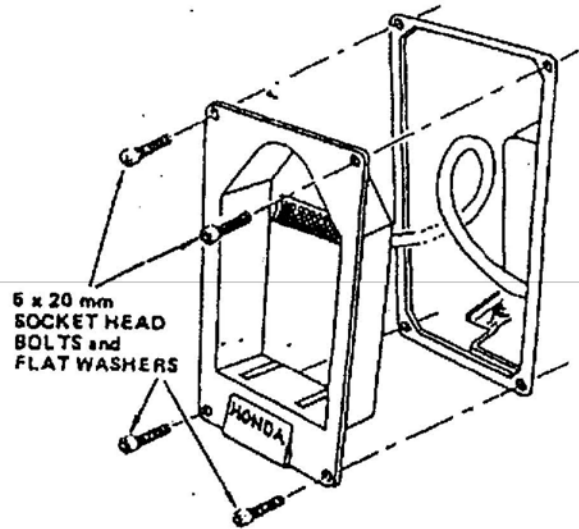

7. Insert the lugs on the bottom of the control unit into the slots in the holder, then press the unit into position until the lock clicks.

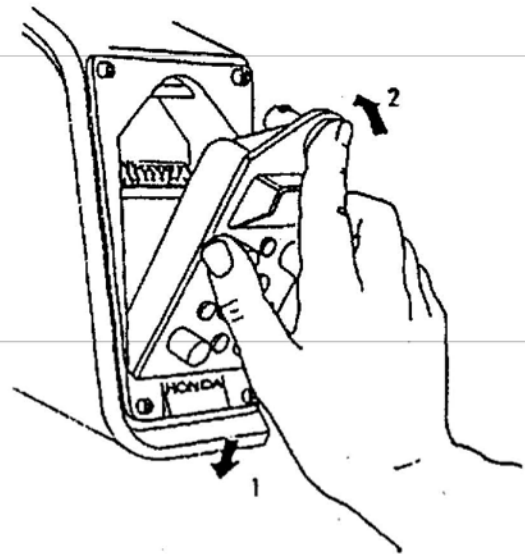

8. Reinstall the fairing. Tighten cap nuts to 1.2 kg-m (9 ft-lb).

goldwingdocs.com

ELECTRICAL CONNECTIONS

Connect all the wires color-to-color using the adapter wire harness. Note that the red fused wire from the power booster and the red/white wire from the radio are connected to the black wire of the adapter.

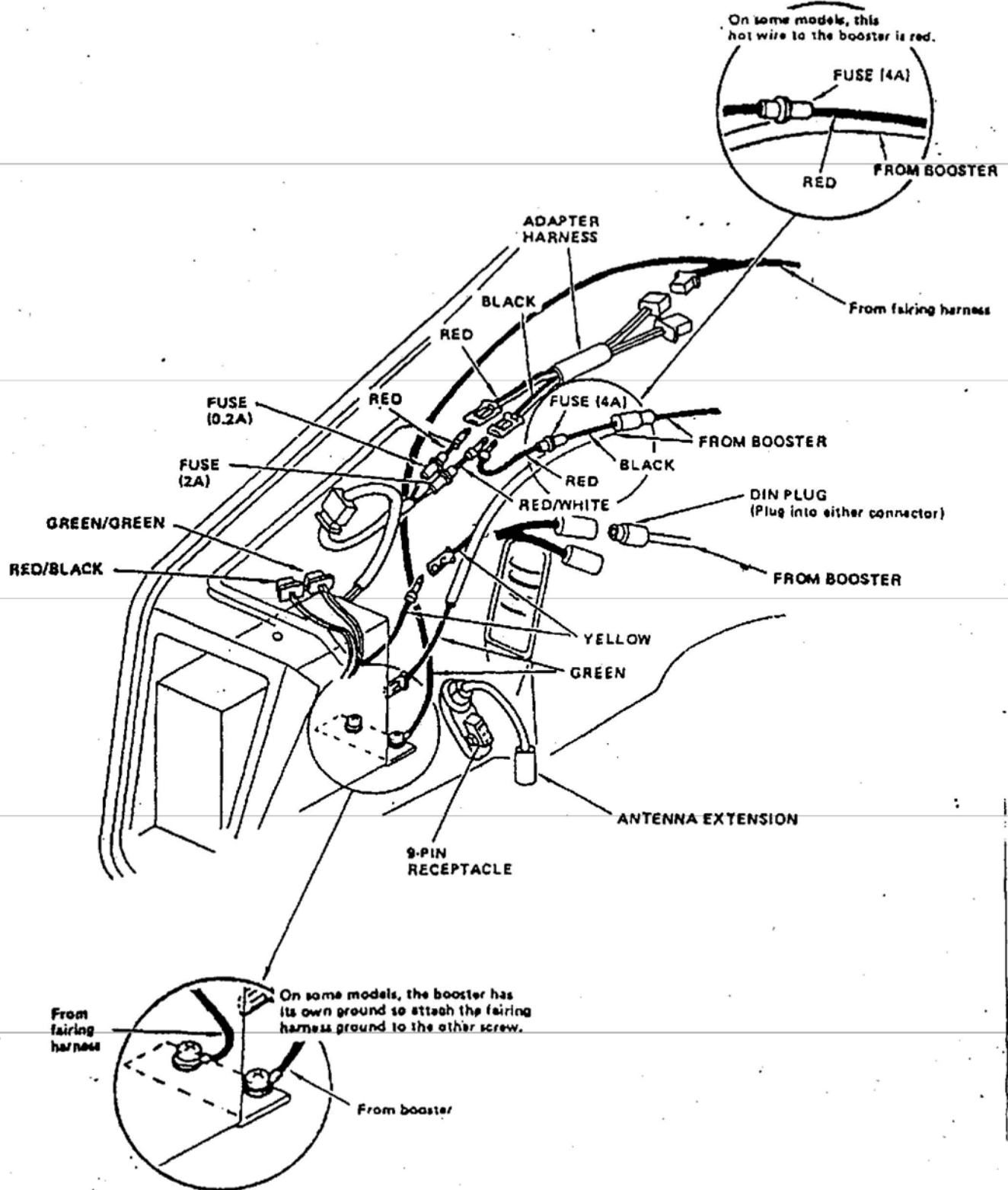

goldwingdocs.com

WIRING DIAGRAM

Plug the 9 pin power connector from the motorcycle into the receptacle in the fairing, then slip the rubber boot over the connector.

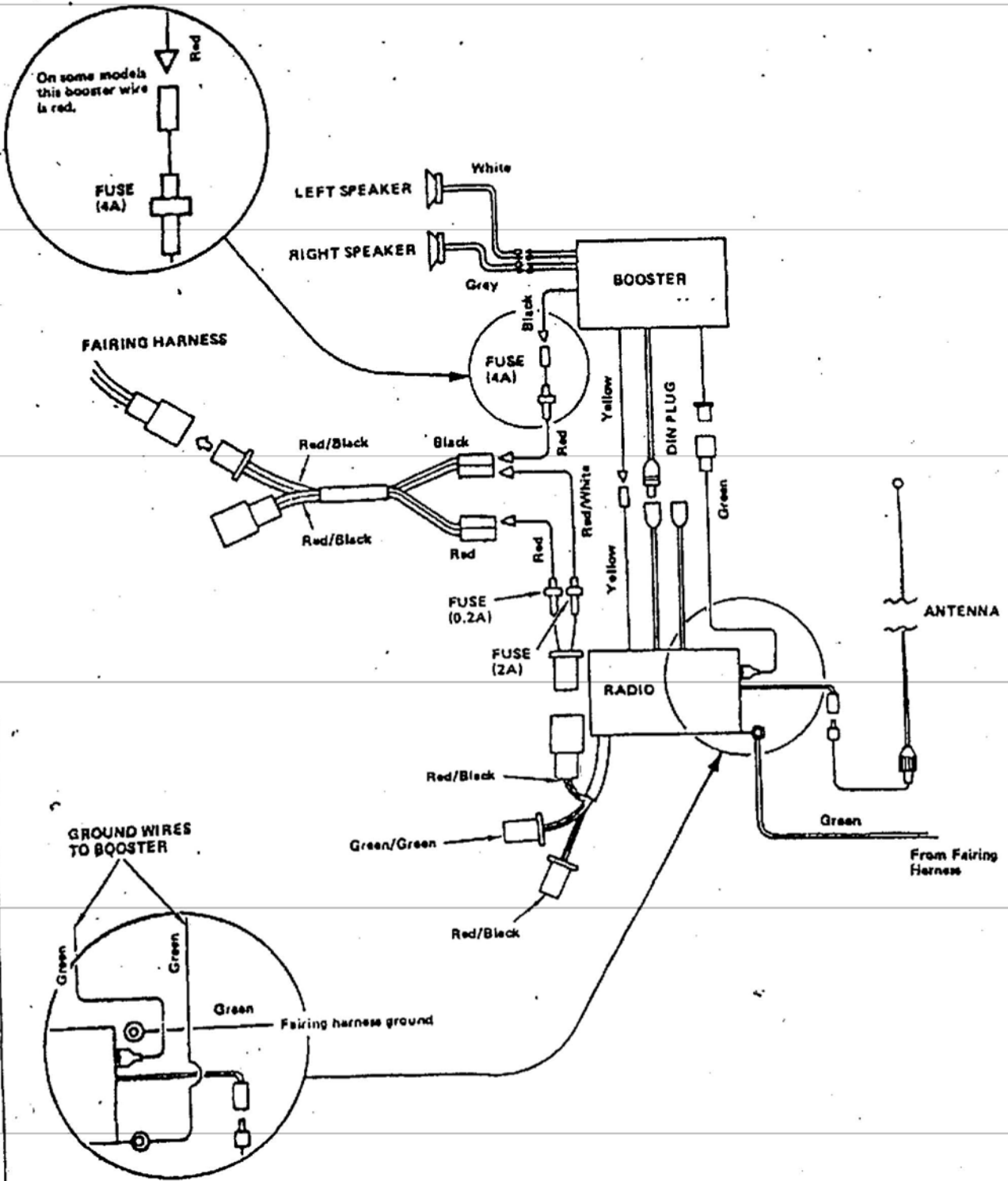

goldwingdocs.com

ANTENNA INSTALLATION

1. Remove the gas tank (or top compartment) and seat.
2. Install the antenna.

CX500C & D, CB650 & C, CB750C & K, and GL1100 for Grab Rail Mount; CB650 & C, and 750F for Trunk Rack Mount:
(Antenna Mount H/C 096395)

- Install the antenna base on the bracket with the special nut provided on the base.
- Then install the antenna bracket on the rear handrail or trunk frame as shown.
- Tighten all bolts and nuts to 1.0 kg-m (7 ft-lb).

GRAB RAIL MOUNT



TRUNK RACK MOUNT

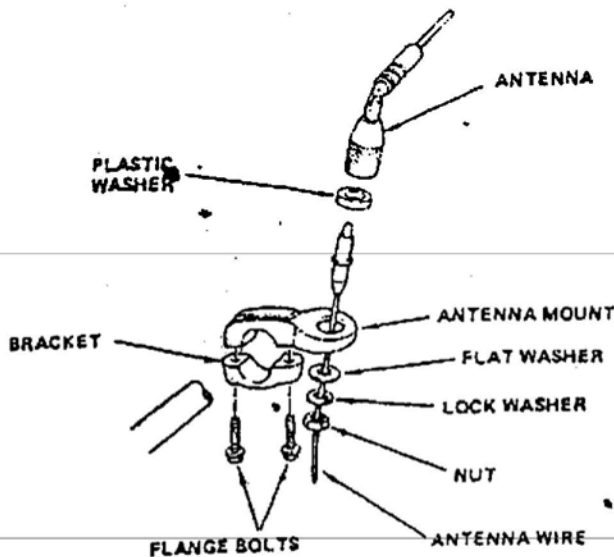
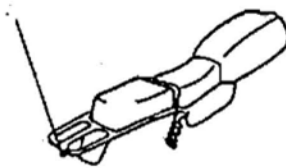

For all other models:

- Remove the rubber grommets from the ends of the antenna mount and split them lengthwise on one side.
- Remove the bracket from the antenna base, route the antenna lead through the mount, then reinstall the rubber grommets at each end.
- Tighten all bolts and nuts to 1.0 kg-m (7 ft-lb).

GL1100I with Travel Trunk:
(Antenna Mount H/C 096526)

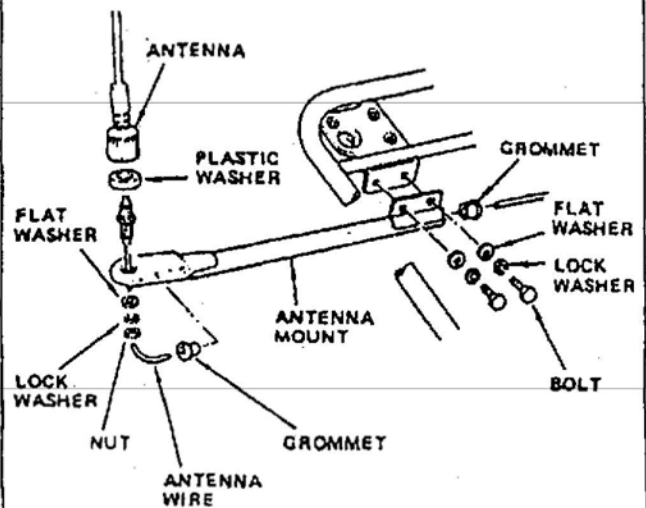

CB750E & K, CB900C, and GL1100 with detachable Travel Trunk platform.
(Antenna Mount H/C 096526)

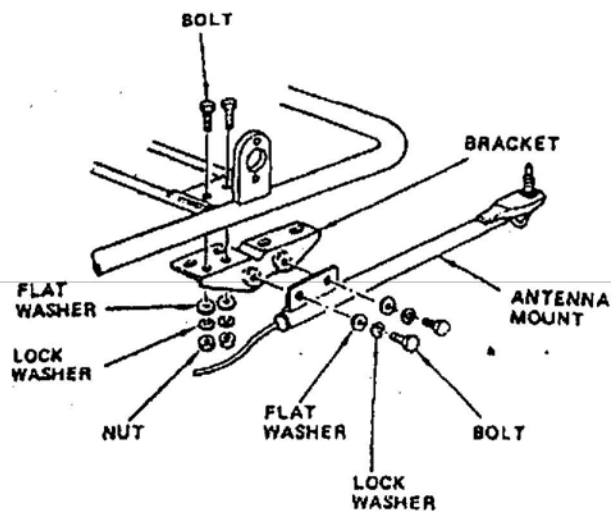

CX500C & D, CB650 & C, CB750C, F, & K, CB900C, and GL1100 with Luggage Rack.
(Antenna Mount H/C 096526)

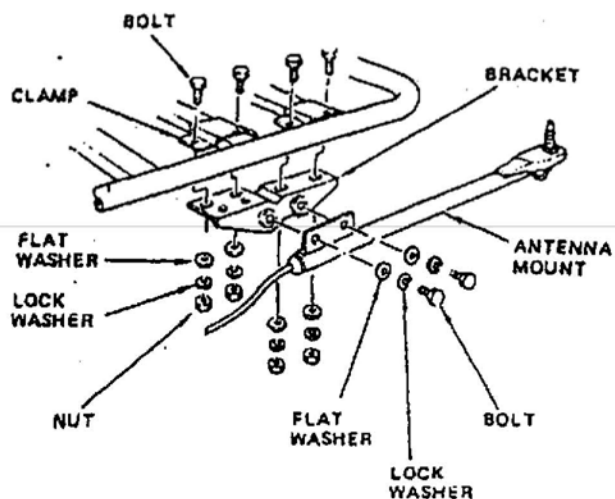

All models with Hondaline Sissy Bar.
(Antenna Mount H/C 101992)

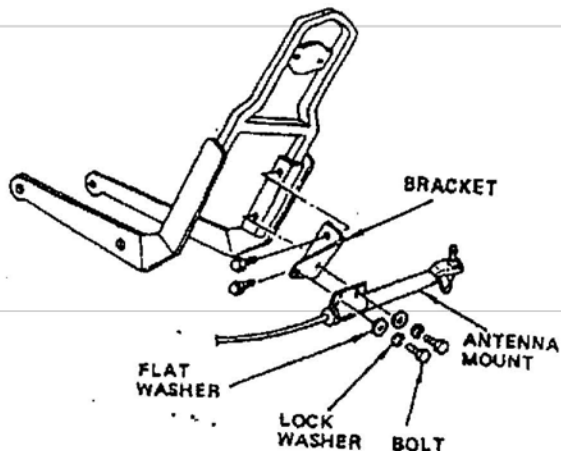

3. Unscrew the knurled locking nut and fold the antenna forward. If necessary, loosen the antenna base nut to adjust the direction of folded position, then retighten the nut.
4. Route the antenna lead forward under the frame cross members and through the grommet in the fairing, then connect it to the antenna extension from the radio.

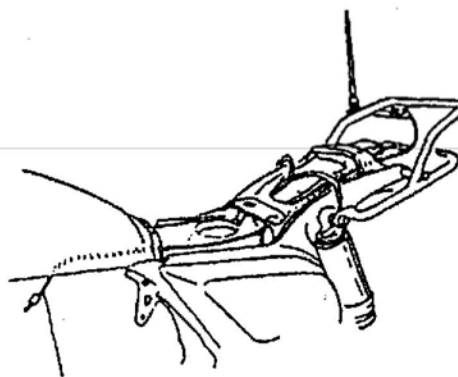

5. Reinstall the seat and fuel tank (or top compartment).

goldwingdocs.com

OPERATING INSTRUCTIONS

Check the operation of the radio before reinstalling the turn signals and the right and left fairing pockets.

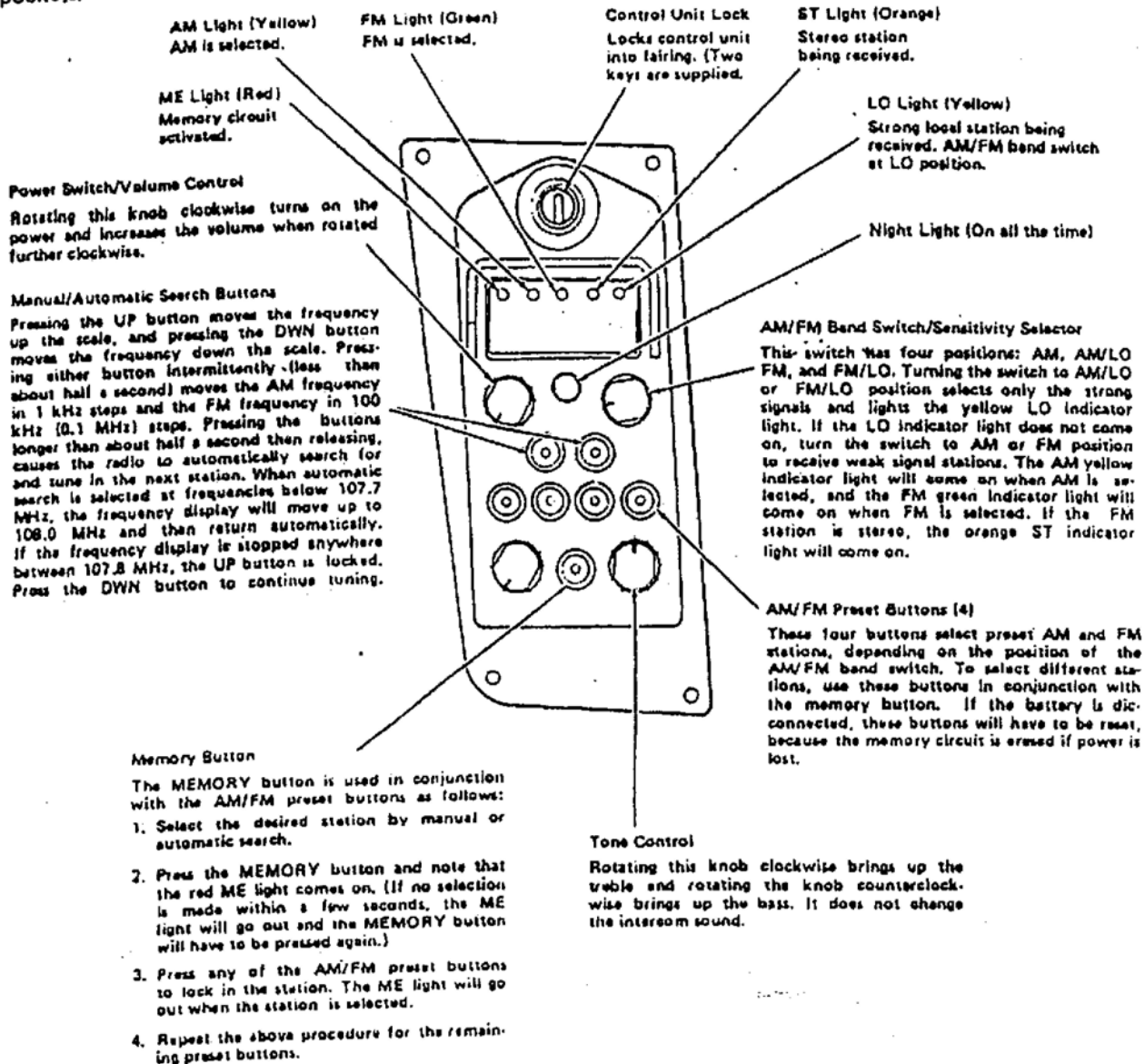

SPECIFICATIONS

- Power/rated voltage 14.0V (10.6-15.8V)
Negative grounded
- Power output 0.1W (400Hz, less than 10% distortion, 8-ohm load)
- Max output power 0.5W
- Current consumption 0.7A max (at 0.1W)
1A max (at 0.5W)
- Speaker impedance 8 ohms (8-16 ohms)

AM radio section

- Frequency range 530 kHz-1606 kHz
- Intermediate frequency 460 kHz
- Maximum sensitivity 26 dB/V

FM radio section

- Frequency range 88 MHz-180 MHz
- Intermediate frequency 10.7 MHz
- Maximum sensitivity 12 dB/V
- Stereo separation Better than 20 dB
- Weight Control unit 0.5 kg
Main unit 1.05 kg

goldwingdocs.com

WIRE ROUTING AND FUSES (Fig. 33)

1) Connect all wires to wire harness terminals properly.

2) Fuses are located in left turn signal base. To replace fuses, remove left turn signal.

Fig. 33

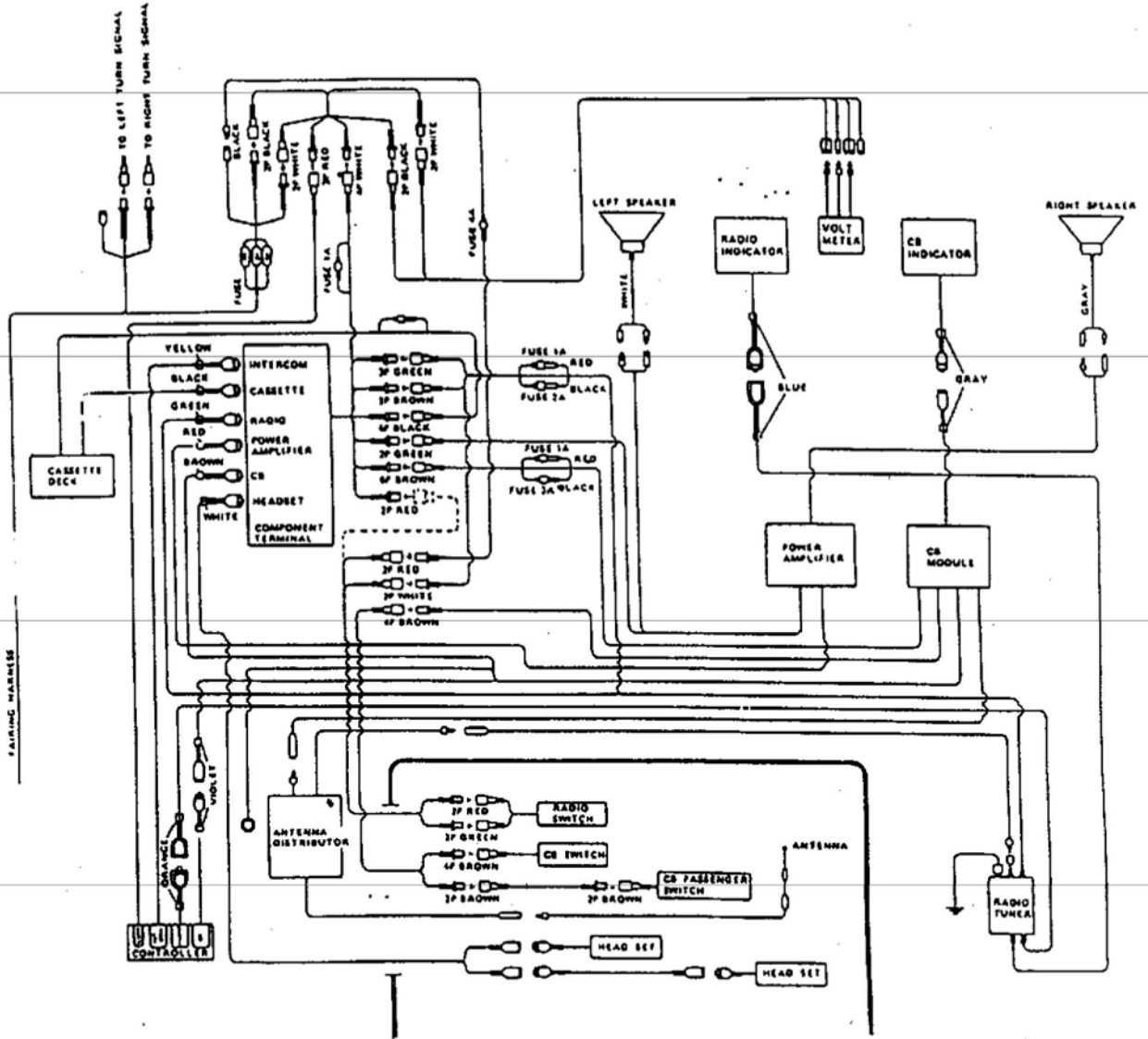

goldwingdocs.com