

PREFACE

Congratulations on purchasing this quality Type 11 Honda Motorcycle Audio system. This booklet is your guide to the installation of your new Type II Honda Motorcycle Radio. Please take the time to read the booklet carefully. (Your authorized Honda dealer will be glad to provide further information or assistance and is equipped to handle your further service needs.)

TOOLS REQUIRED

- Ratchet and 12" extension
- 7 and 10 mm sockets
- 8, 10, and 14 mm box wrenches
- Drill
- 1/8", 7/32", 3/16", and 1/4" Bits
- 2.5, 4, 8 mm hex wrench
- #1 and #2 Phillips screwdrivers
- Sharp knife or Razor blade
- Hammer
- Center punch
- Masking tape
- 17 mm open-end wrench

PARTS LIST

■ AM/FM stereo Tuner

Fig. 1

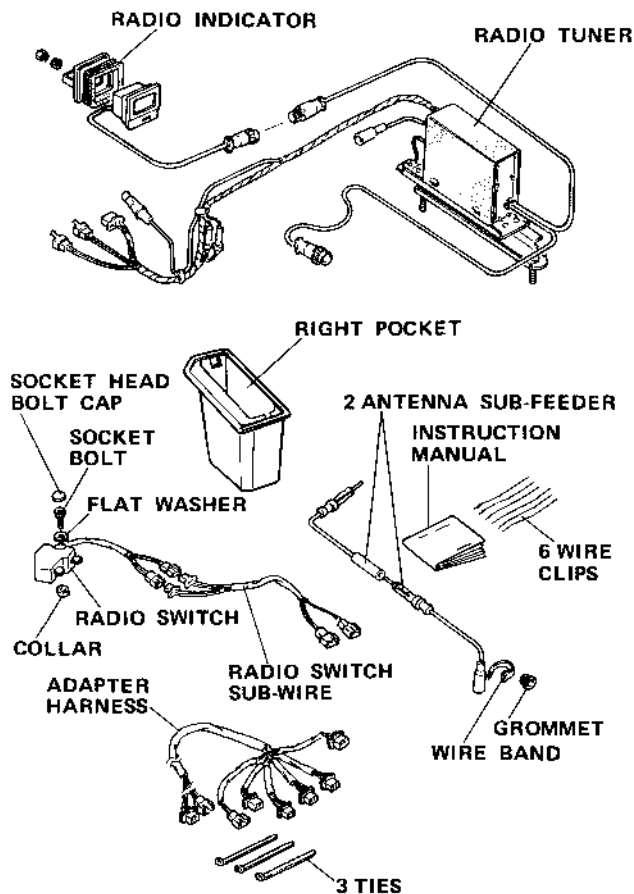

■ Detachable Control Panel

Fig. 2

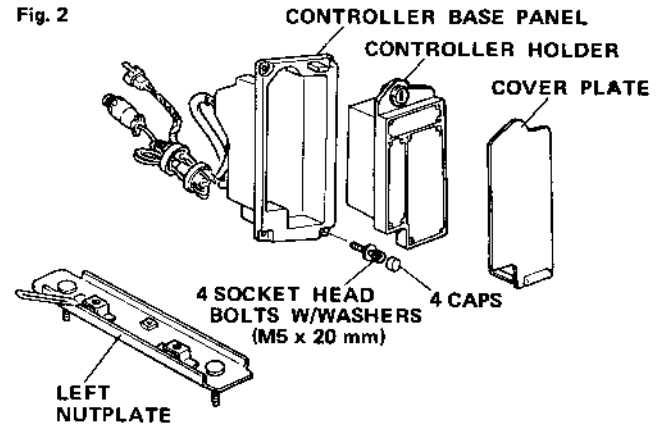

■ Digital Indicator Panel

Fig. 3

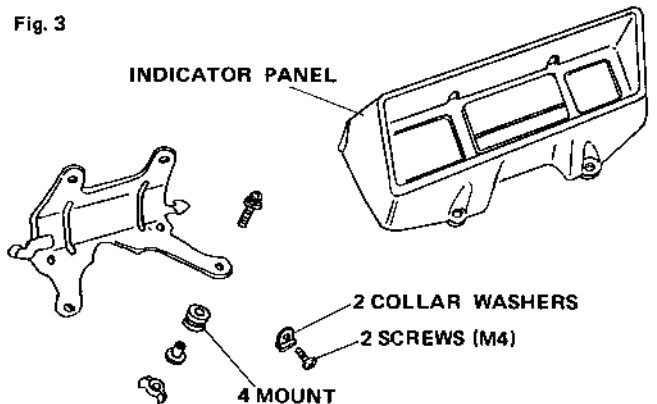

goldwingdocs.com

■ Power Amplifier

Fig. 4

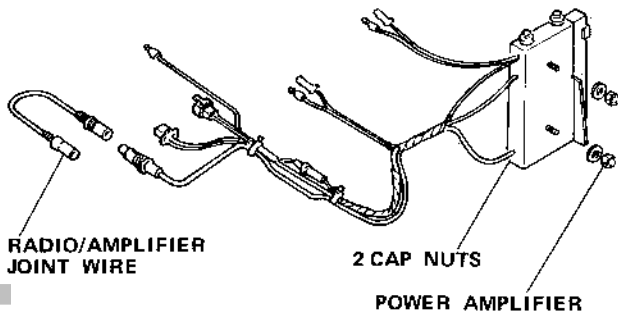

■ Speaker

Fig. 5

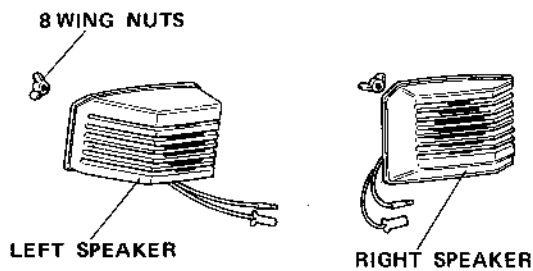

■ Type II AM/FM/CB Antenna

Fig. 6

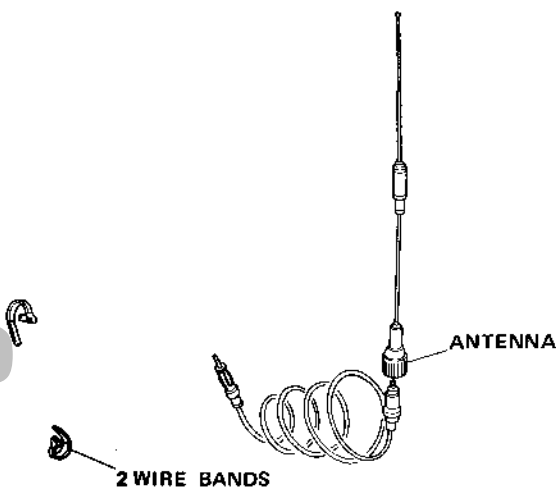

■ Antenna Mount Ass'y

There are three types of antenna mount, type A, and B, available. Choose the right type for your motorcycle.

● Type A

Use this type for motorcycle which has a trunk carrier or a luggage rack.

Fig. 7

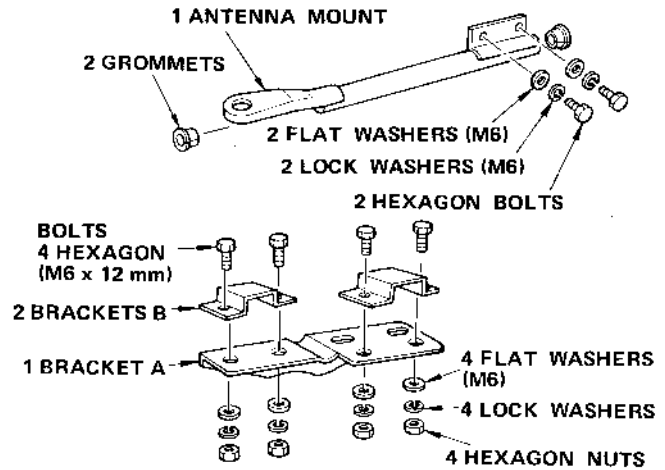

● Type B

Use this type for a motorcycle which has no carrier but only a rear seat guard pipe.

Fig. 8

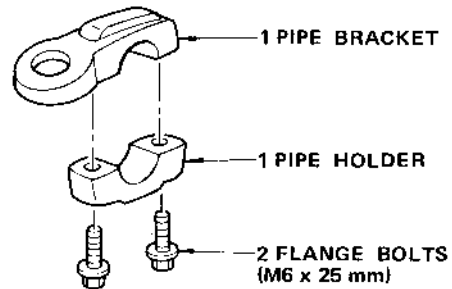

OVERALL LAYOUT

Fig. 9

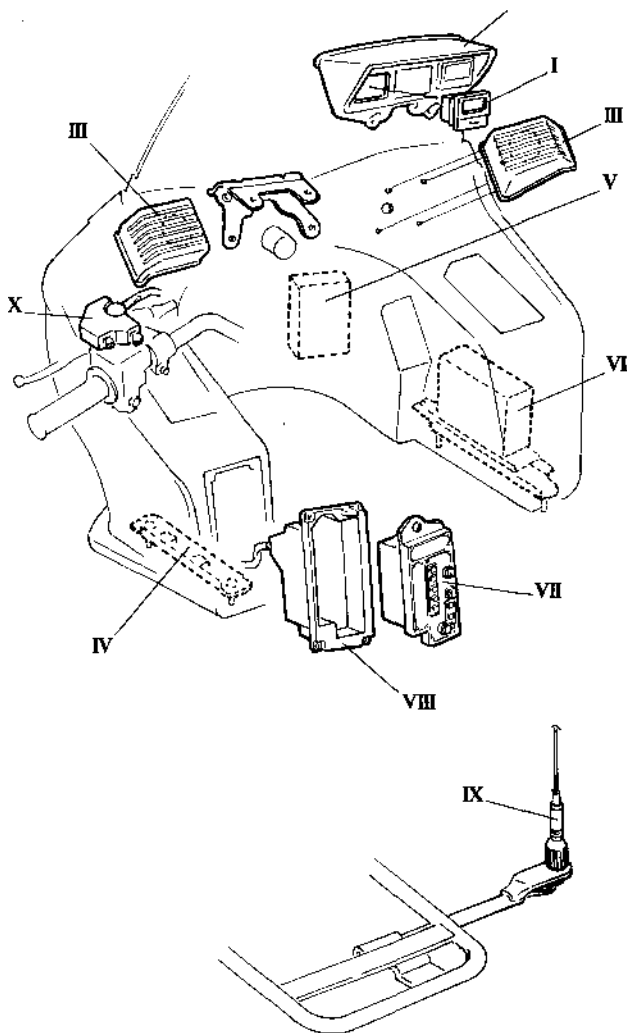

INSTALLATION

Outline Procedures

This section gives general information needed for mounting the individual radio components on and in the fairing.

A) Fairing

- 1) Install radio on fairing before mounting fairing on motorcycle. (Remove fairing from your motorcycle when already mounted).
- 2) Remove fairing parts.
- 3) Drill unit mount holes.
- 4) Install six wire clips.
- 5) Install windshield on fairing before installing speakers.
- 6) Install radio indicator I on indicator panel II, then install indicator panel on fairing.
- 7) Install speakers III.
- 8) Install nutplate IV.
- 9) Install Power Amplifier in fairing.
- 10) Install radio tuner VI.
- 11) Install the radio controller VII.
- 12) Install controller base panel VIII
- 13) Install radio switch sub-wire.
- 14) Connect adapter harness and wires inside fairing by working through left turn signal lens hole.

B) Motorcycle frame and handlebar

- 1) Remove travel trunk and seat. Unscrew four shelter bolts (M6, one on each side at front and rear) to route antenna feeder.
- 2) Install antenna mount and antenna IX.
- 3) Route antenna feeder along the frame tube.
- 4) Install radio switch X on left handlebar lever bracket and route the wires

C) Fairing installation

- 1) Install fairing on motorcycle.
- 2) Connect motorcycle wire harness 9-P coupler to fairing wire 9-P coupler.
- 3) Connect radio switch wire to switch sub-wire.
- 4) Connect antenna feeder.
- 5) Confirm that radio operates properly. Reinstall parts removed in step 2 or (A) and in step 1 of (B).

REWORKING

Remove Fairing and Fairing Parts (Fig.10)

- 1) Install radio on fairing before mounting fairing on motorcycle. (Remove fairing from your motorcycle when already mounted).
- 2) Remove right and left fairing pockets, right and left turn signal lenses, right and left nutplates, left hole cover and indicator base panel from fairing. (Fig.10)

Fig. 10

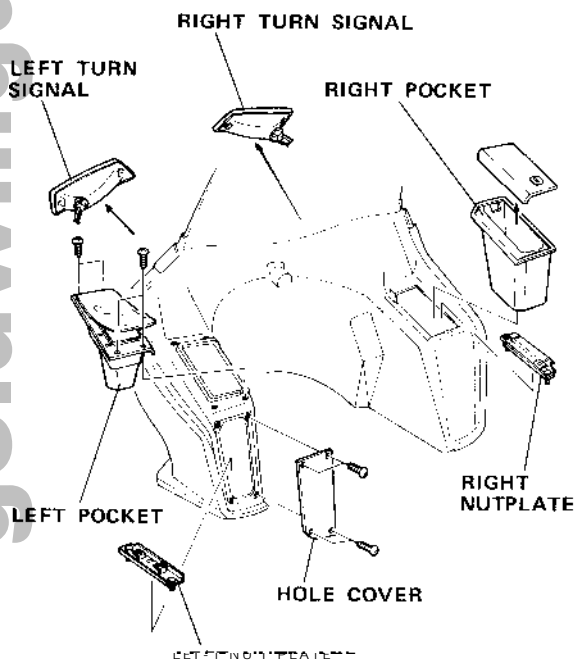

Reworking on Fairing —

Speaker mounting holes-

- 1) Remove 18 mm grommet.
- 2) Lightly roll template so that it will follow contour of fairing snugly.
- 3) Position template on fairing with its upper and outer edges aligned with those of fairing as indicated by arrows.
- 4) Attach template to fairing using adhesive tape where shown.
- 5) Punch mark centers of four holes with a drift and hammer.
- 6) Drill 6 mm holes through marked centers.

To obtain a more balanced response with richer, deeper bases, drill two 50 mm holes in the fairing so as to link the speaker box with the inside of the fairing.

Fig. 11-1

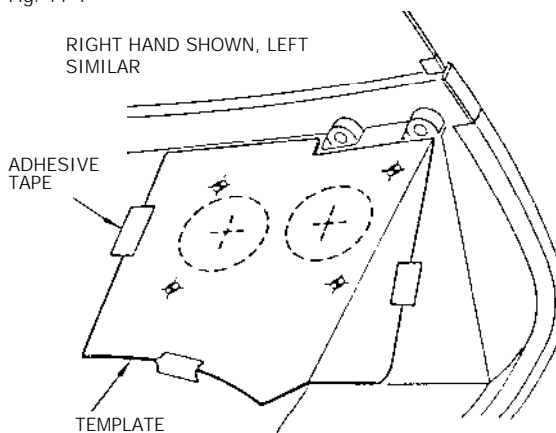

—Power amplifier mounting holes-

- 7) Drill two 5.5 mm holes through concaves in fairing.

Fig. 11-2

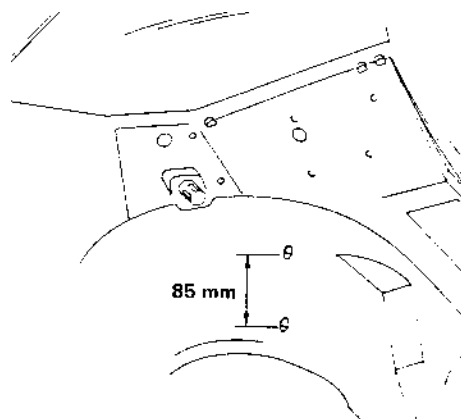

—Indicator panel mounting holes—

- 8) Drill four 15 mm holes through fairing at the marked locations, and 40 mm holes as shown.

Fig. 11-3

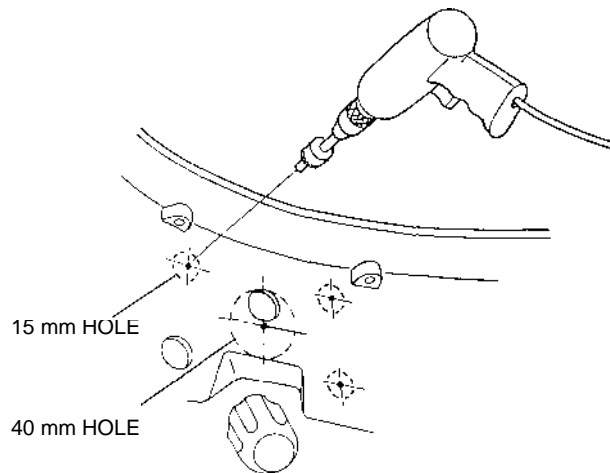

- 9) Install six wire clips to temporarily secure wires as shown.

Fig. 11-4

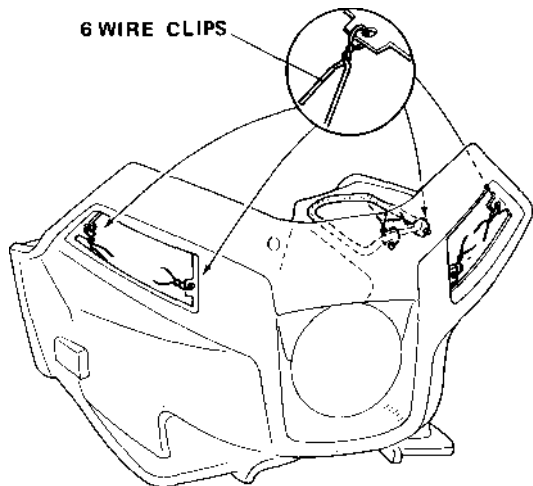

INSTALLATION ON FAIRING

Radio Indicator Installation (Fig. 12, 13, 14)

- 1) Install radio indicator in indicator panel as shown.

Fig. 12

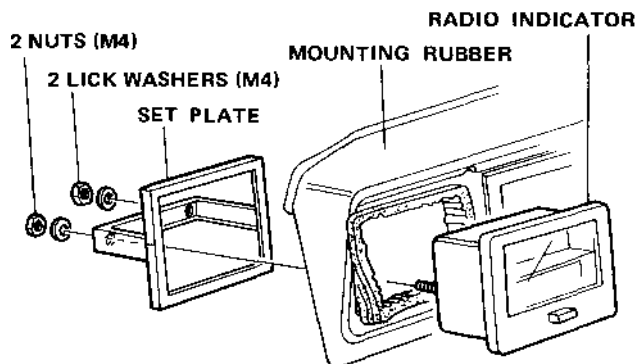

- 2) Insert the cushion rubbers into the holes with the thick ends facing out.
- 3) Slide special washers into cushion rubbers from inside fairing.
- 4) Attach the top of the base bracket to fairing using two screw-washer combinations and wing nuts. Tighten wing nuts with pliers while holding the screws with screwdriver.

Fig. 13

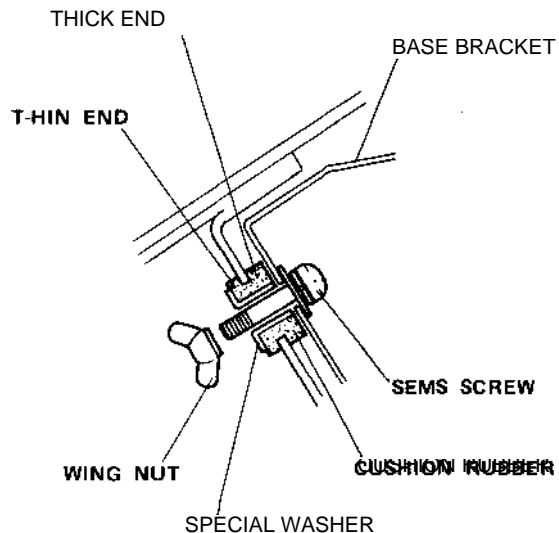

- 5) Install indicator panel on base bracket.
- 6) Route indicator wire out through right turn signal lens hole and sub-wire harness G out through left turn signal lens hole. Temporarily secure wires with wire clips.

Fig. 14

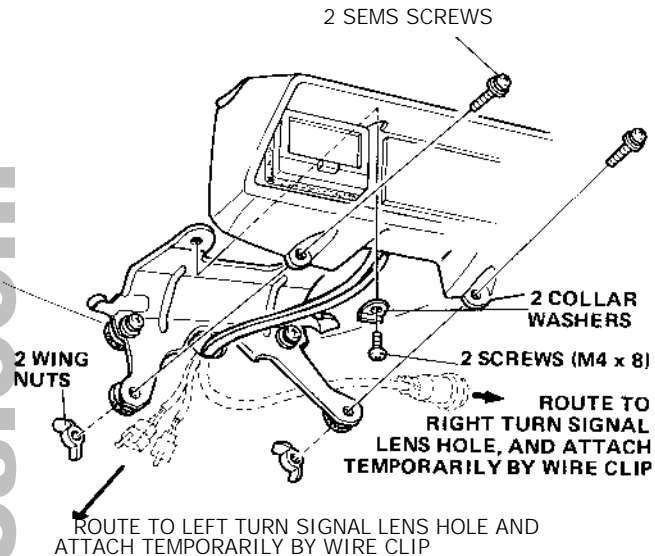

Speaker Installation (Fig. 15)

- 1) Route speaker wires through holes in fairing and position each speaker in fairing align studs with holes in fairing.
- 2) Reaching through the turn signal lens holes, install wing nuts on studs and tighten securely.

Fig. 15

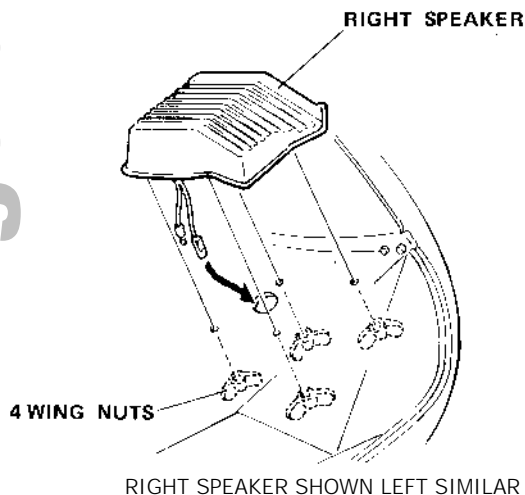

Left Nutplate Installation (Fig. 16)

- 1) Install left nutplate as shown.

Fig. 16

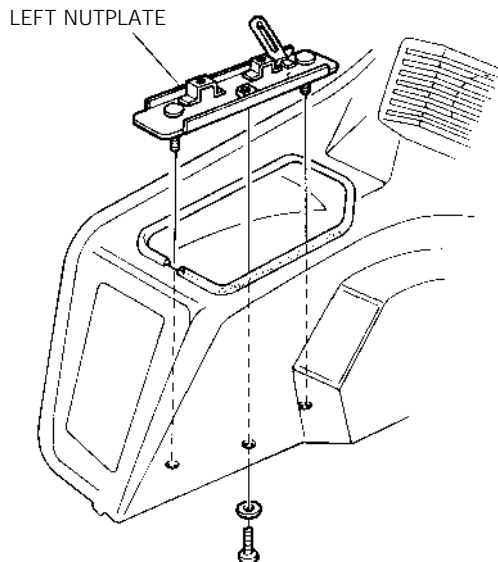

Power Booster Installation (Fig. 17)

- 1) Insert booster into fairing through right turn signal lens hole.
- 2) Insert booster studs into holes in fairing and install using a cap nut on each stud. Tighten securely.
- 3) Route the gray wire out to right turn signal lens hole and connect to wire from right speaker.
- 4) Route wires bundled with yellow tape under headlight and out through left turn signal lens hole.
- 5) Remove yellow tape from wires and connect white wire to left speaker wire. Temporarily secure other wires with wire clips.

Fig. 17

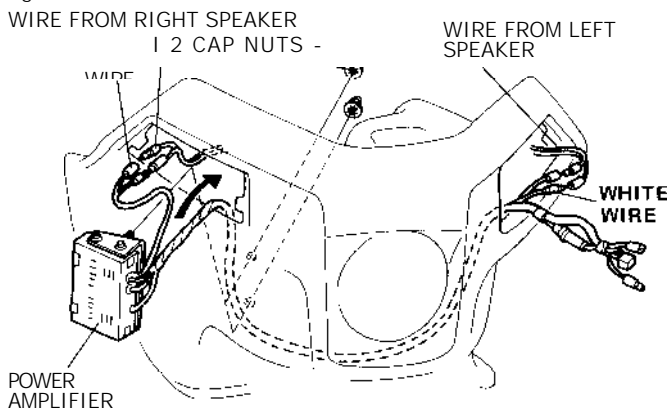

Radio Tuner Installation (Fig. 18, 19)

- 1) Attach right nutplate with radio to fairing.

Fig. 18

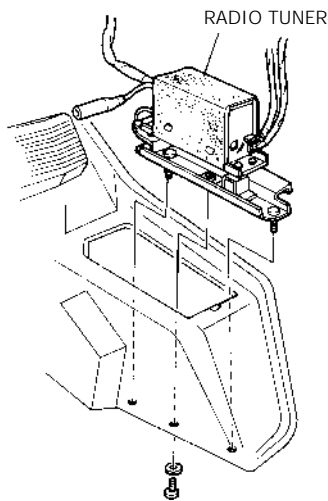

- 2) Route wires bundled with green tape under headlight towards left and out through left turn signal lens hole. Temporarily secure wires with wire clip.
- 3) Route wire to radio controller under headlight towards left side and out through left pocket hole. Secure wire with wire clip temporarily.
- 4) Pass indicator wire out through right turn signal lens hole and connect it to wire from indicator.
- 5) Connect two antenna feeders to radio and route them out through hole above 9-P connector.

Fig. 19
WIRES BUNDLED WITH YELLOW TAPE

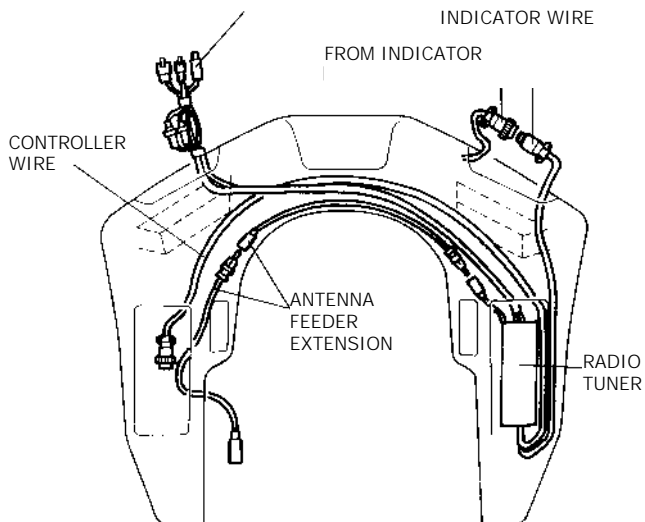

Radio Controller Installation (Fig. 20)

Remove radio controller blind lid from controller holder. Slide the radio controller into the holder and install using four hex socket bolts.

Fig. 20

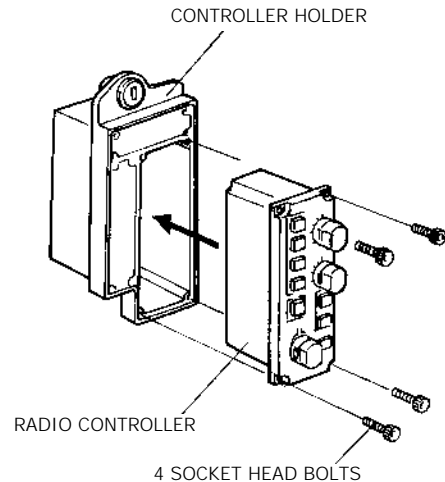

Controller Base Panel Installation (Fig. 21, 22)

- 1) Slide controller base plate into fairing and install using four socket head bolts. Place caps over heads of socket bolts.

Fig. 21

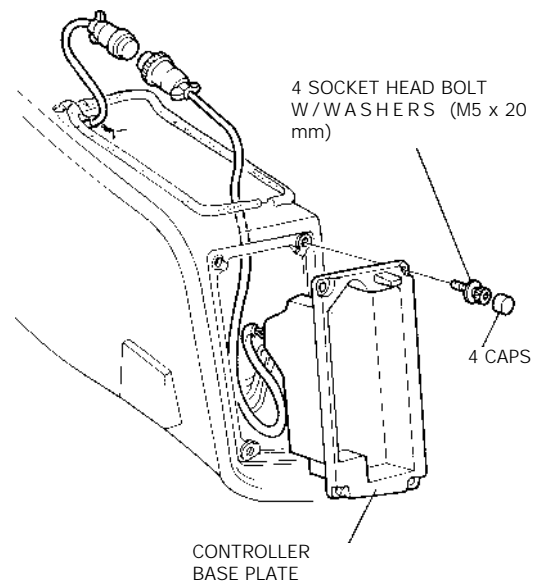

- 2) Route radio wires out through left pocket hole and connect them to wires from radio. Insert wires into fairing. Secure wires and antenna feeder with wire clamp on nutplate.

Fig. 22

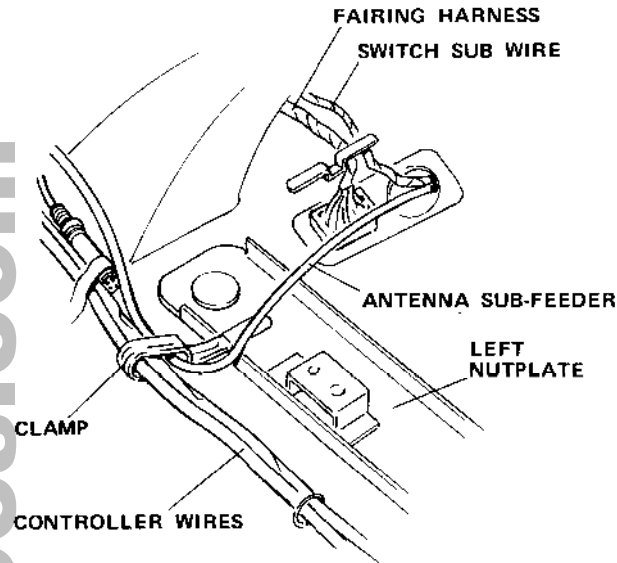

Radio Switch Sub-wire Routing (Fig. 23)

- 1) Route radio switch sub wire out through left turn signal lens hole and secure with wire clip as shown.

Fig. 23

RADIO SWITCH SUB-WIRE

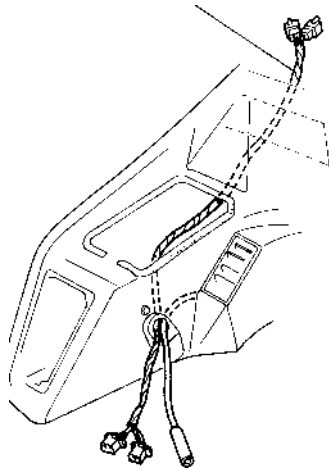

Routing Wires Inside Fairing (Fig. 24, 25)

- 1) Bundle six harness wires passed out of left turn signal lens hole (not yet connected) with ties ① and ② (A in Fig. 20).
- 2) Connect radio/booster joint wires (B in Fig. 20).
- 3) Connect adapter harness (C in Fig. 20).
- 4) Connect radio switch sub harness (D in Fig. 20).
- 5) Connect power booster harness (E in Fig. 20).
- 6) Bundle wires and harnesses with ties as shown (F in Fig. 20).

Fig. 24

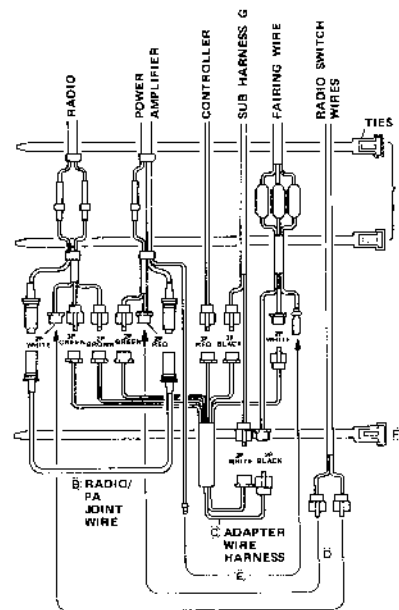

- 7) Press all bundled wires and wire harness into fairing through left turn signal lens hole.

Fig. 25

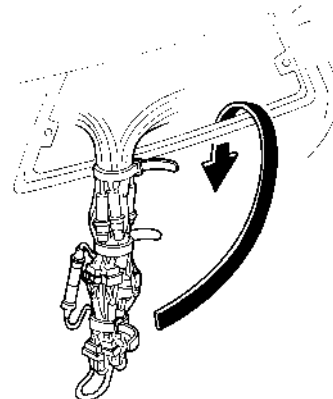

Antenna Installation (Fig. 26, 27, 28, 29)

- 1) Remove seat by removing hex socket bolts (one on each side) and pulling it backward.
 - 2) Remove the top compartment by removing four bolts (M6) (one on each side at front and rear) and pulling it upward. See Motorcycle Service Manual.
 - 3) Install antenna on antenna mount and route antenna feeder through mount. Antenna is collapsible. Install the antenna so it folds along the frame. This is for convenience when covering the motorcycle, or putting the motorcycle in a garage.
- 4-1 Press grommets into holes at ends of mount. Position antenna mount on rear trunk stay and install using bolts w/washers.
- Tighten nuts (M12) to 0.1 kg-m torque.
 - Tighten hexagon bolt (M6 x 12 mm) to 0.8-1.2 kg/m (6-9 ft/lb) torque.

Fig. 26

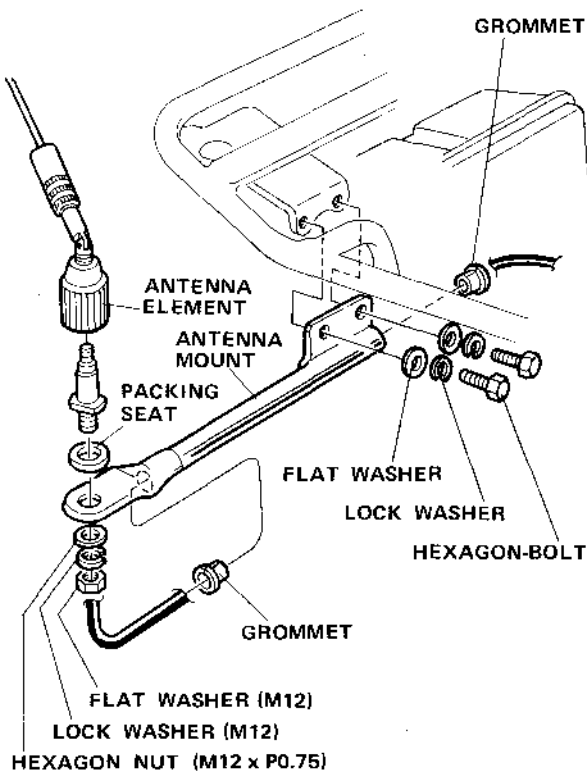

Fig. 27

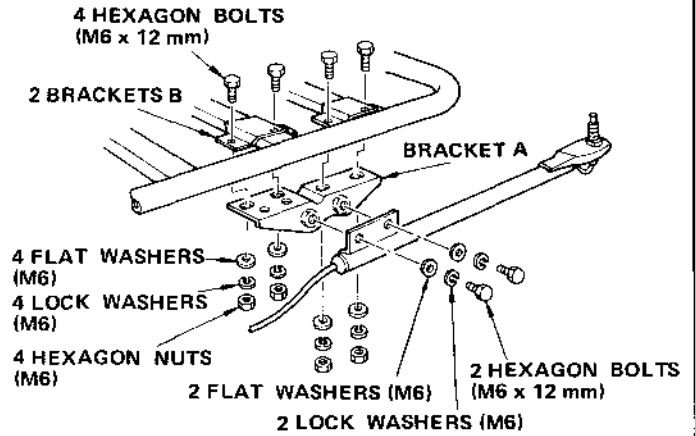
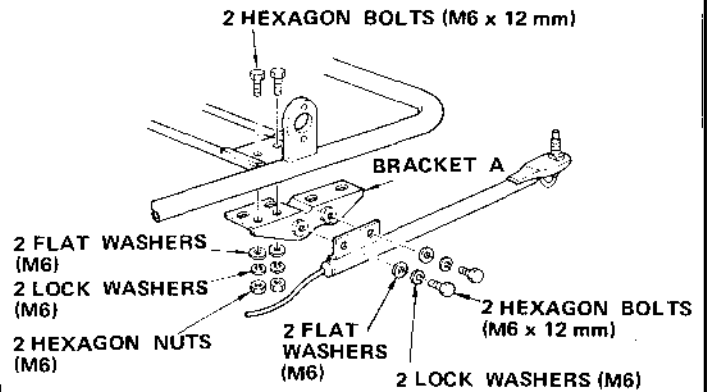

Fig. 28



- 4-2 Position antenna base on seat guard pipe and install using bracket, holder and two flange bolts (M6 x 25 mm).

- Tighten the flange bolt (M6 x 25 mm) to 0.8-1.2 kg/m (6-9 ft/lb) torque.
- Tighten the hexagon nut (M12) to 0.1 kg/m torque.

Fig. 29

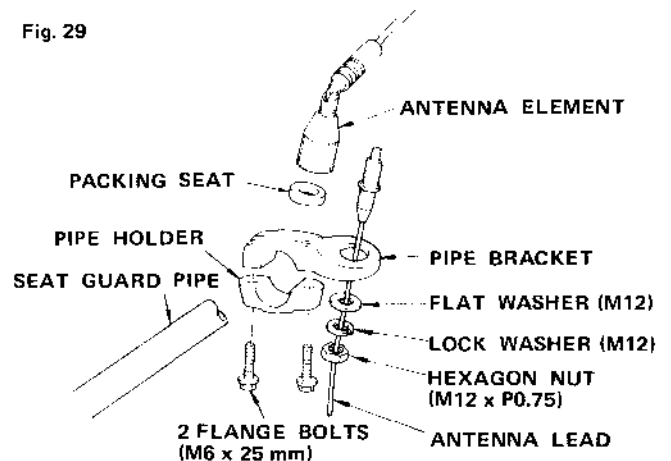

Antenna Feeder Routing (along frame tube) (Fig. 30, 31)

Route antenna feeder as shown.

Fig. 30

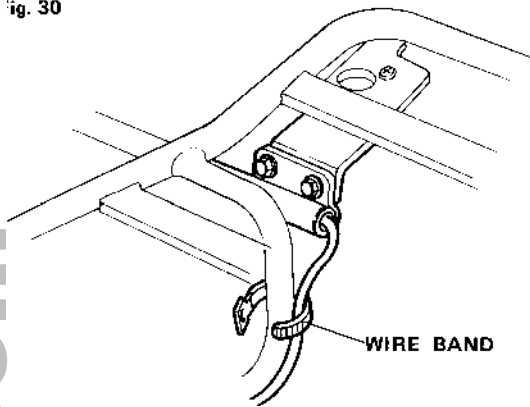
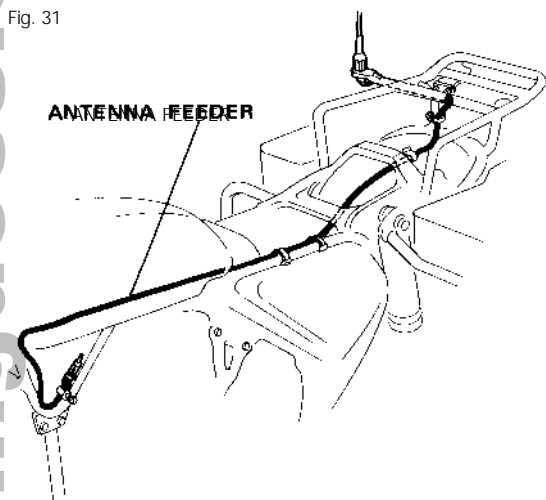

Fig. 31



Radio switch installation (Fig. 32, 33)

- 1) Remove plug from left handlebar lever bracket and install radio switch.

Fig. 32

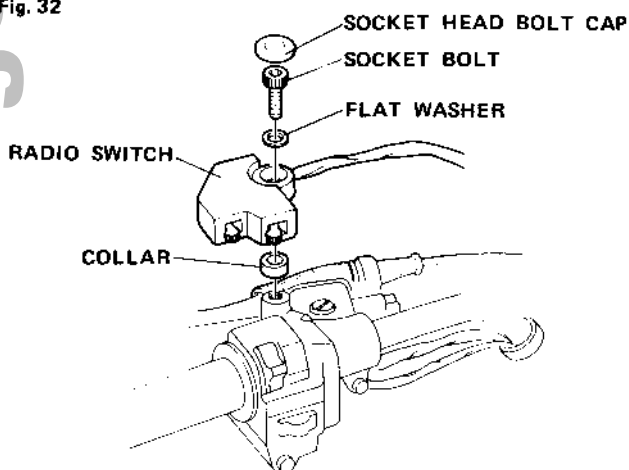

- 2) Route switch wires along with turn signal switch wires, and attach them to handlebar with wire bands positioned where shown.

Fig. 33

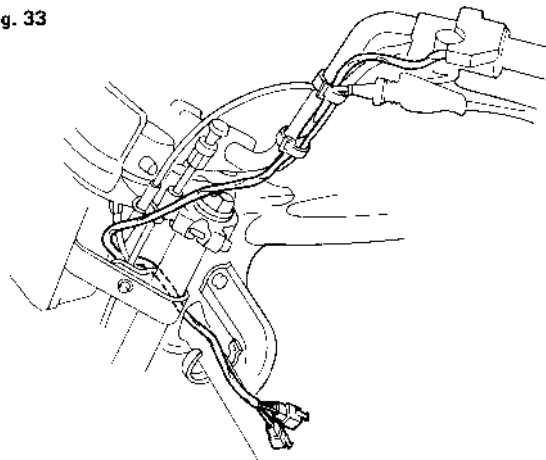

Fairing Installation (Fig. 34)

- 1) Install fairing on motorcycle.
- 2) Connect motorcycle wire 9-P connector and ground wire to fairing connector and ground connection. Place connector cover over connections.
- 3) Connect radio switch wires to switch sub-harness wires.
- 4) Connect antenna feeder to feeder extension and attach it to fairing mount frame with wire band.

Fig. 34

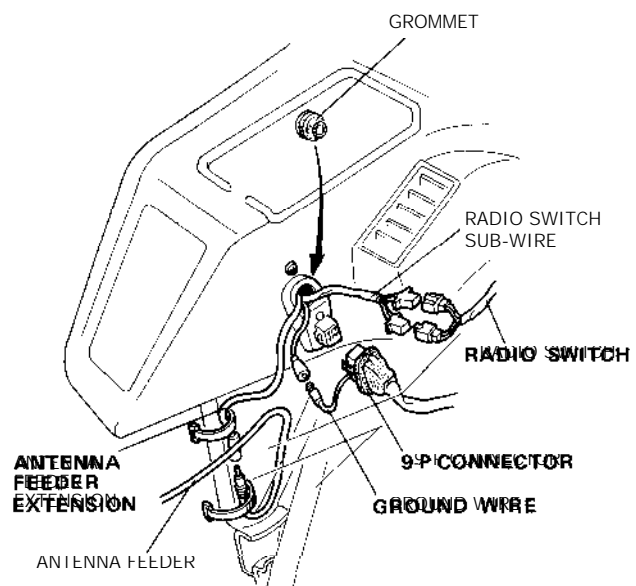

WIRE ROUTING AND FUSES (Fig. 35)

- 1) Connect all wires to wire harness terminals properly.
- 2) Fuses are located in left turn signal base. To replace fuses, it is necessary to remove left turn signal.

Fig. 35

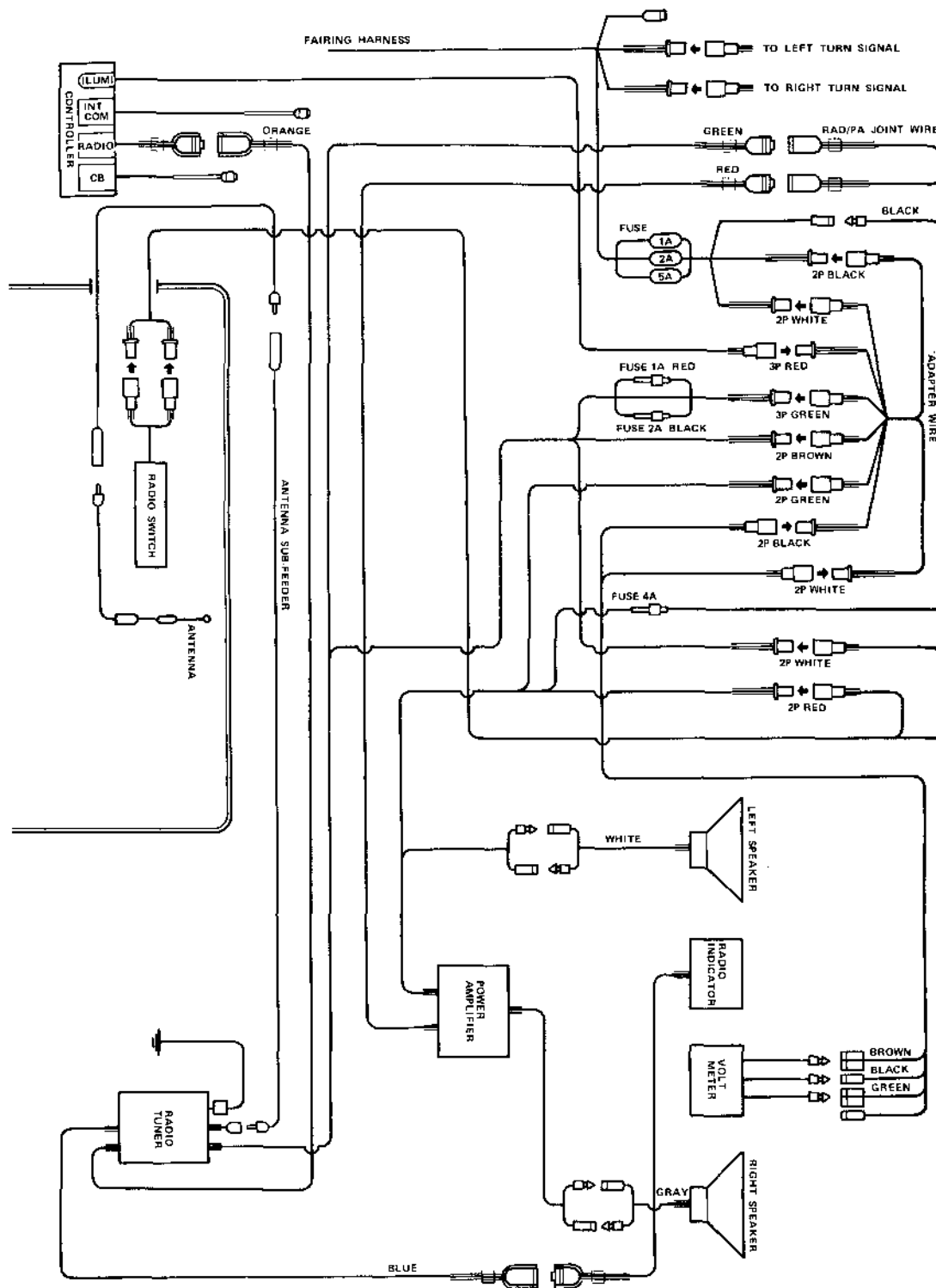

PREFACE

Congratulations on purchasing this quality Hondaline Type II Audio system. This booklet is your guide to the installation of your new Hondaline Type II Intercom, CB Transceiver Cassette Deck. Please take the time to read the booklet carefully. (Your authorized Honda dealer will be glad to provide further information or assistance and is equipped to handle your further service needs.)

TOOLS REQUIRED

- Ratchet and 12" extension
- 7 and 10 mm Sockets-
- 8, 10, and 14 mm Box wrenches
- Drill
- 1/8", 7/32", 3/16", and 1/4" Bits
- 2.5, 4, 8 mm Allen wrench
- #1 and #2 Phillips screwdrivers
- Sharp knife or Razor blade
- Hammer
- Centerpunch
- Masking tape
- 17 mm open-end wrench

PARTS LIST**Intercom**

Fig. 1

**CB Transceiver**

Fig. 2



■ Cassette Deck

Fig. 3

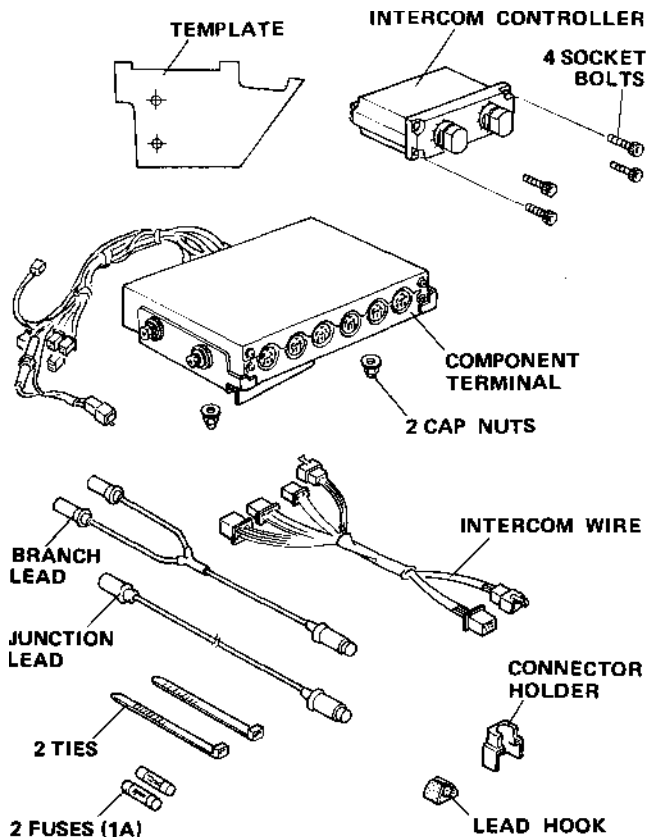
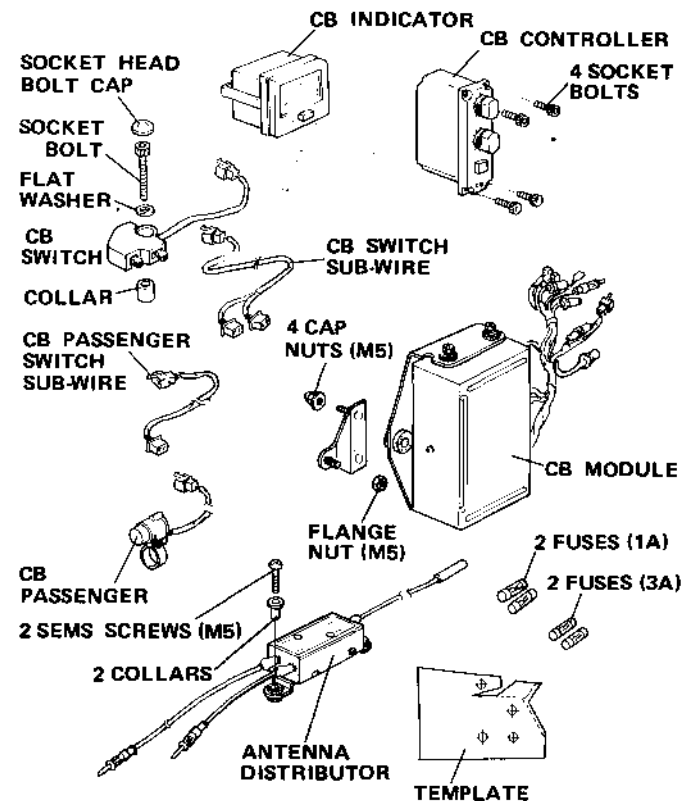
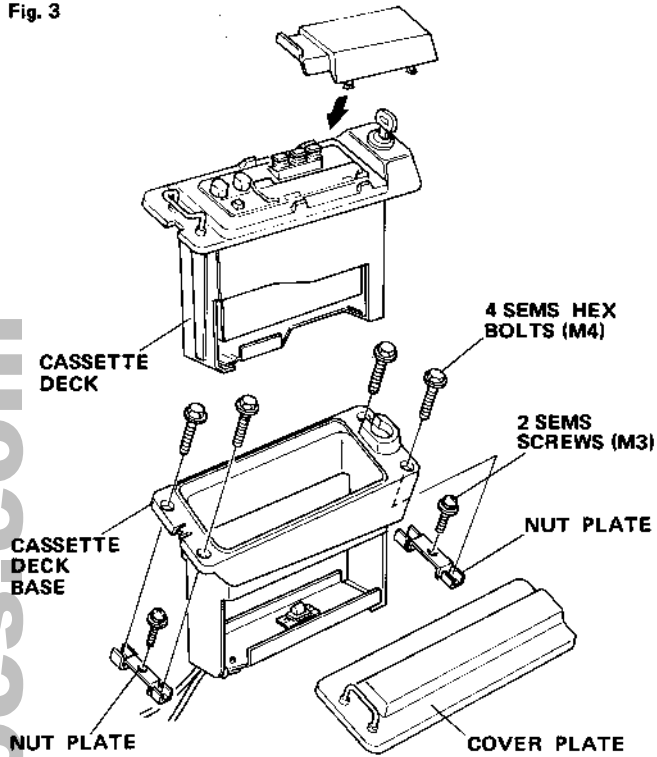

OVERALL LAYOUT

Fig. 4

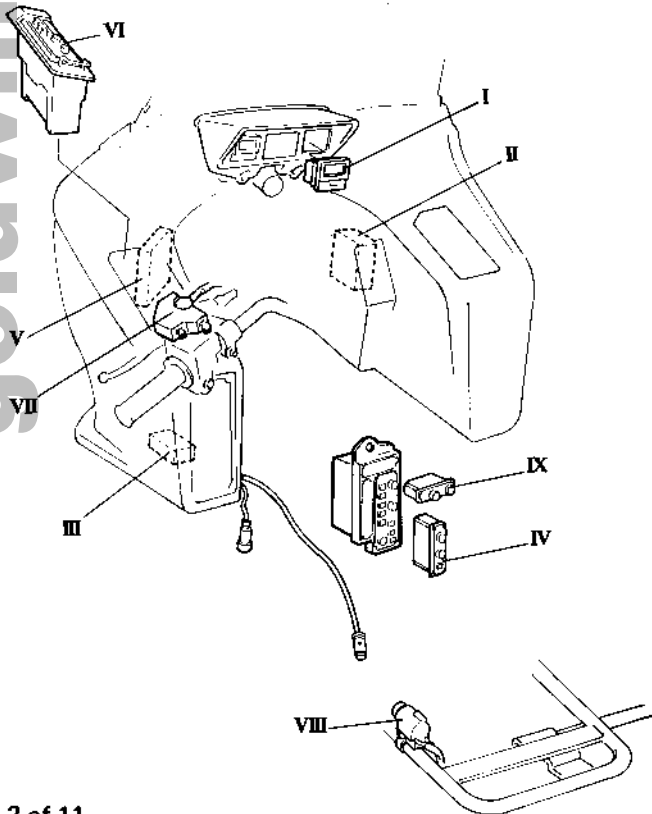

INSTALLATION

Outline Procedures

This paragraph deals with general outline information needed for mounting the individual components on the fairing.

- 1) Remove fairing and fairing parts.
- 2) Drilling unit mount holes.
- 3) Install six wire clips.
- 4) Remove some radio parts.
- 5) Install CB indicator I on indicator panel, then install indicator panel on fairing.
- 6) Install CB module II.
- 7) Install Antenna distributor III.
- 8) Install CB switch sub wire.
- 9) Install CB controller N. and Intercom controller IX.
- 10) Install Component terminal V.
- 11) Install Branch lead.
- 12) Plug in all connectors to component terminal.
- 13) Route wires inside fairing.
- 14) Install Cassette deck VI.
- 15) Install CB Switch VII on left handle lever bracket and route wire.
- 16) Install CB Passenger switch VIII.
- 17) Route Junction lead along with frame pipe.
- 18) Install fairing on motorcycle and connect wires.
- 19) Confirm that all system operate properly. Reinstall parts removed in step 1.

REWORKING

Remove Fairing and Fairing Parts (Fig. 5)

- 1) Remove fairing from your motorcycle when already mounted.
- 2) Remove right and left fairing pockets, right and left turn signal lenses, right and left nutplates and left hole cover indicator base panel from fairing (Fig. 5).

Fig. 5

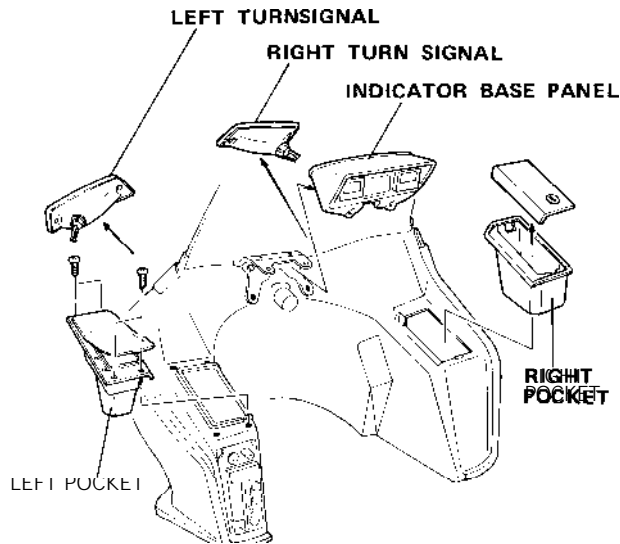

Reworking on fairing (Fig. 6, 7, 8, 9) (

Drilling component terminal, CB module and cassette deck mount holes)

—CB, component terminal—

- 1) Lightly roll template so that it will follow contour of fairing snugly.
- 2) Position template on fairing with its upper and outer edges aligned with those of fairing as indicated by arrows.
- 3) Attach template to fairing using adhesive tape where shown.
- 4) Punch mark centers of four holes with a drift and hammer.
- 5) Drill 6 mm holes through marked centers.

Fig. 6

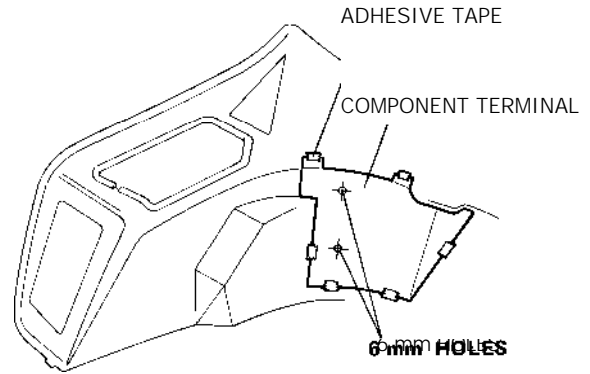
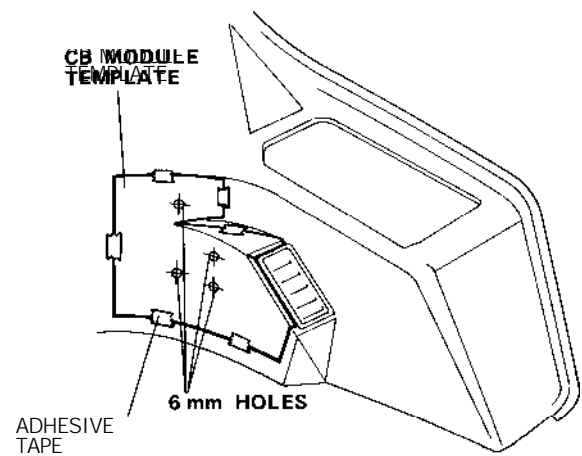

Fig. 7



—Cassette deck—

- 6) Punch mark centers of two holes with a drift and hammer.
- 7) Drill 6 mm holes through marked centers.

Fig. 8

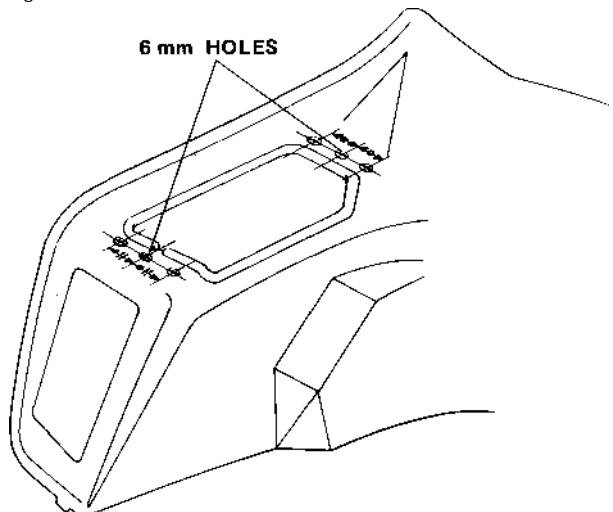

- 8) Install six wire clips to temporarily secure wires as shown.

Fig. 9

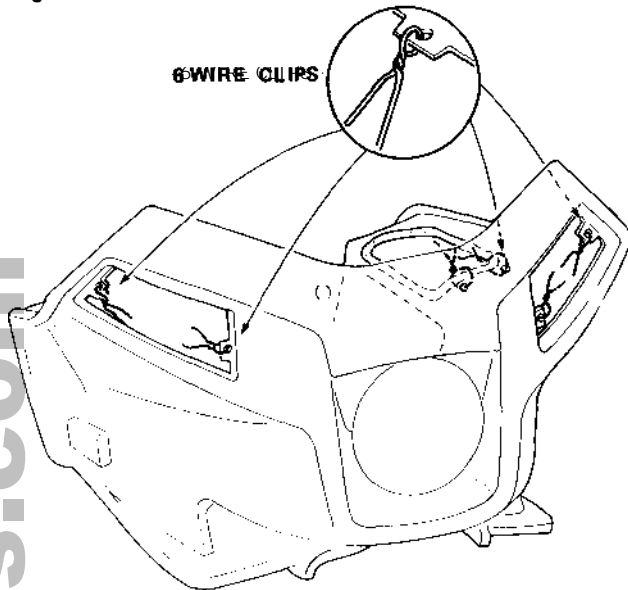

- 9) Install windshield on fairing before installing speakers.

Removing Radio Parts (Fig. 10, 11, 12)

Remove several radio parts from fairing as follows when already radio mounted.

- 1) Pull out bundled wires through left turn signal lens hole.

Fig. 10

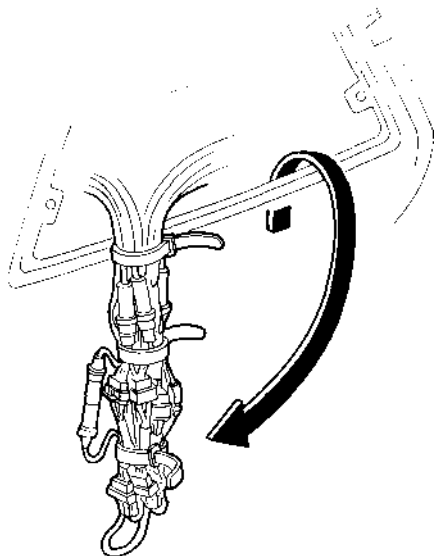

- 2) Unbundle three ties and disconnect adapter wire harness and RADIO/PA JOINT WIRE.

Fig. 11

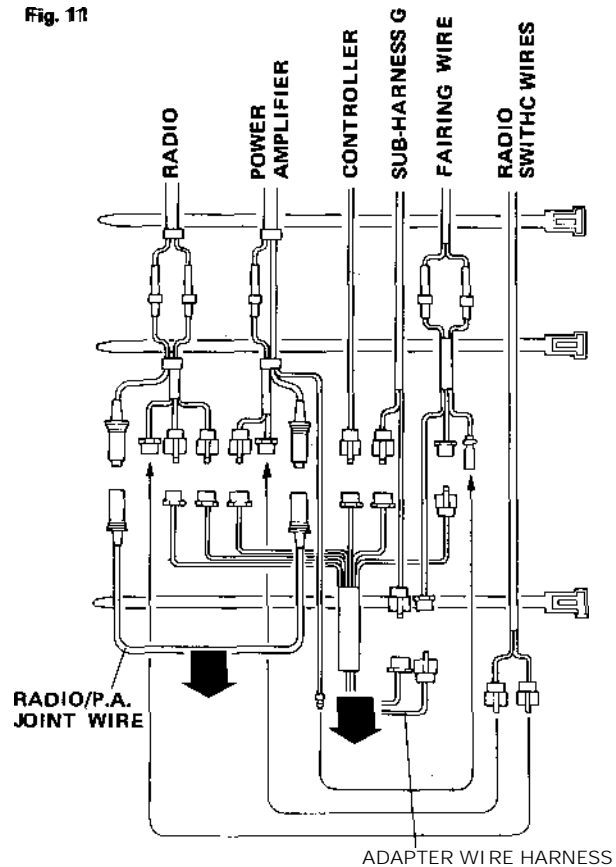

- 3) Disconnect and remove one antenna feeder of two.

Fig. 12

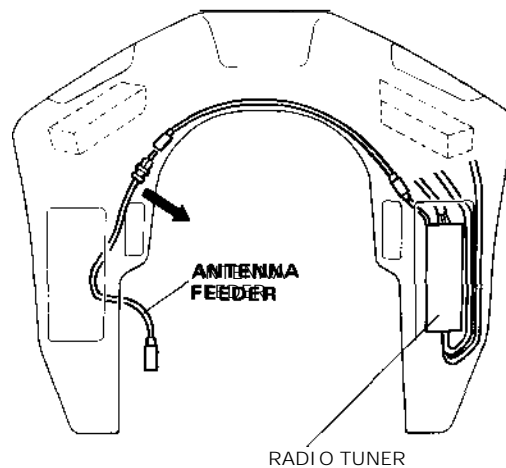

INSTALLATION ON FAIRING

CB

CB Indicator Installation (Fig. 13, 14, 15, 16)

- 1) Install CB indicator in right hole of indicator panel. (Remove indicator panel from fairing when already mounted. Remove volt-meter from right hole when already mounted and install it in central hole and install two blind lid in both side hole of volt-meter.)

Fig. 13

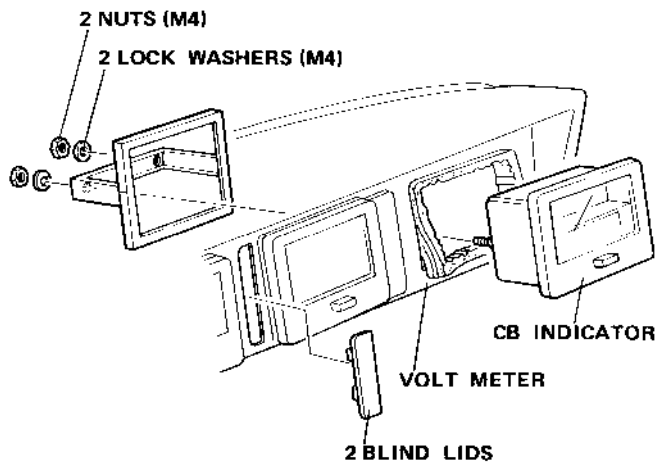

- 2) Reinstall indicator panel on base bracket.
- 3) Rout indicator panel wire out through right turn signal less hole.

Fig. 14

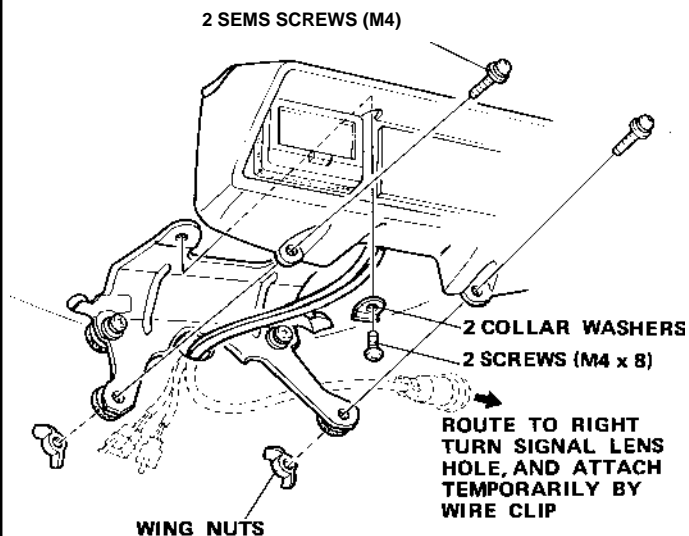

CB Module Installation (Fig. CB-3)

- 1) Insert CB module and CB bracket (not yet assembled) into fairing through right pocket hole.
- 2) Insert CB module studs into holes in fairing and install using a cap nut on each stud loosely.
- 3) Insert CB bracket stud into holes of CB module and then insert studs into holes and install using a flunge nut on stud loosely.
- 4) Insert CB bracket stud into holes in fairing and install using a cap nut on each stud loosely.
- 5) Tighten flunge nut securely first, and then 4 cap nuts.

Fig. 15

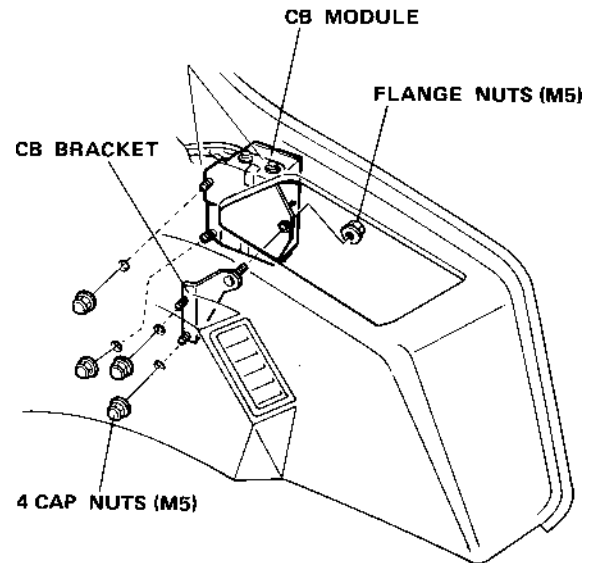

- 6) Route wires (with fuses and miniture connectors) under headlight and out through left turn signal lens hole. Temporarily secure wires with wire clips.
- 7) Route wires bounded with yellow tape under headlight and out through left pocket hole.
- 8) Remove yellow tape from wires and secure wires with wire clip temporarily.
- 9) Pass indicator wire out through right turn signal lens hole and connect it to wire from CB indicator.

Fig. 16

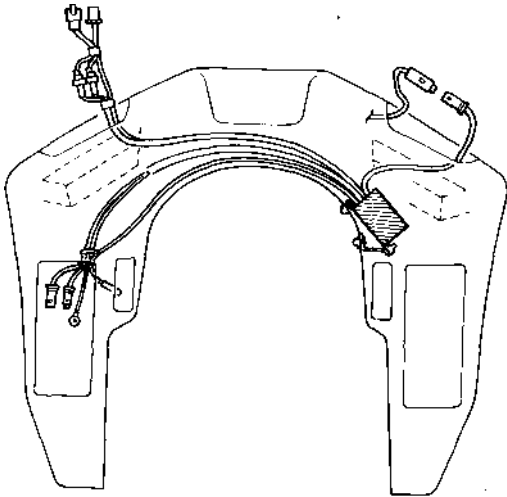

Antenna Distributor Installation (Fig. 17, 18)

- 1) Install antenna distributor on left nut plate as shown.

Fig. 17

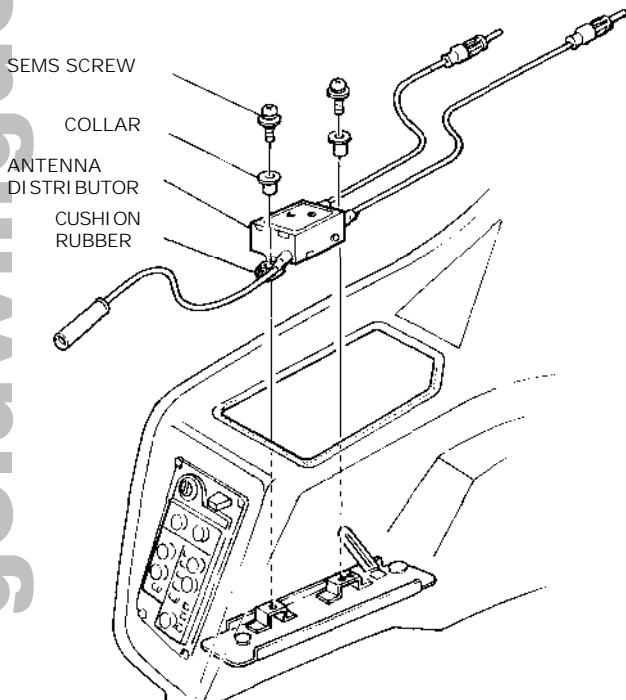

- 2) Pass antenna feeder of distributor indicated "ANTENNA" out through round hole above 9-pin connector.
- 3) Connect antenna feeder of distributor indicated "AM/FM RADIO" to antenna feeder from radio tuner.
- 4) Connect antenna feeder of distributor indicated "CB-SET" to antenna feeder from CB module.
- 5) Connect CB controller wire to wire from CB module.
- 6) Tighten green ground wire with double sems screw.

Fig. 18

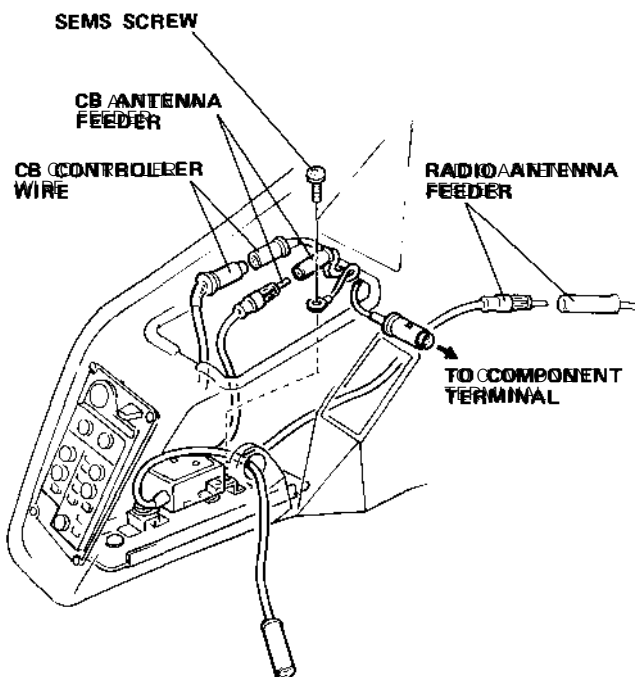

CB Switch Sub Wire Installation (Fig. 19)

- 1) Route CB switch sub-wire out through left turn signal lens hole and secure with wire clip as shown. (Route along radio switch sub wire)

Fig. 19

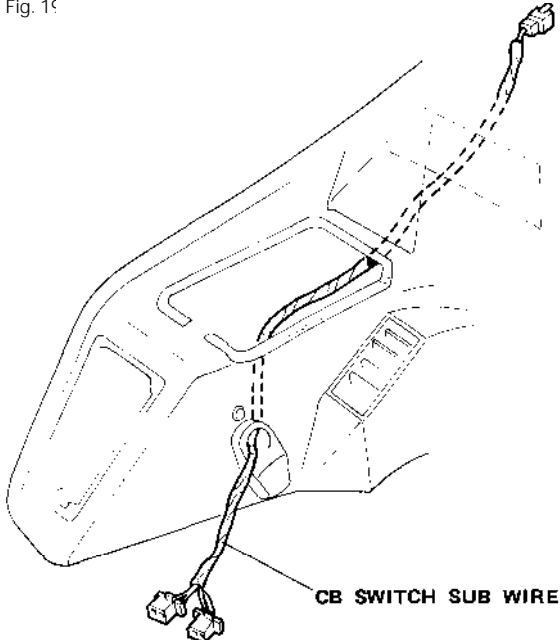

Component Terminal Installation (Fig. 21)

- 1) Insert component terminal into fairing through left turn signal lens hole.
- 2) Insert component terminal studs into holes in fairing and install using a cap nut on each stud. Tighten securely.
- 3) Pull out wires through left turn signal lens hole and secure with wire clip.

Fig. 21

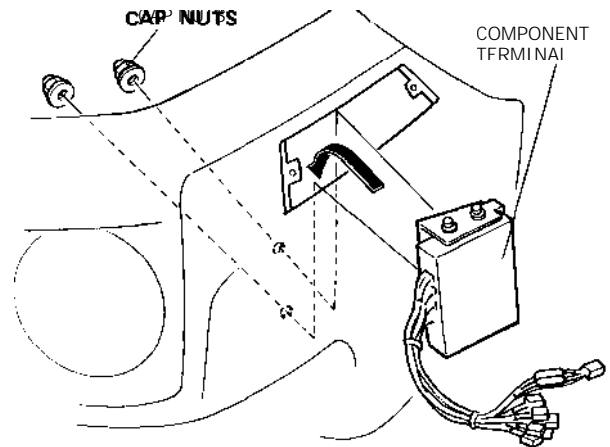

Branch Lead Installation (Fig. 22)

- 1) Pass branch lead in through hole above 9-pin connector and plug in to component terminal.
- 2) Attach lead hooks and secure branch lead with them where shown.

Fig. 22

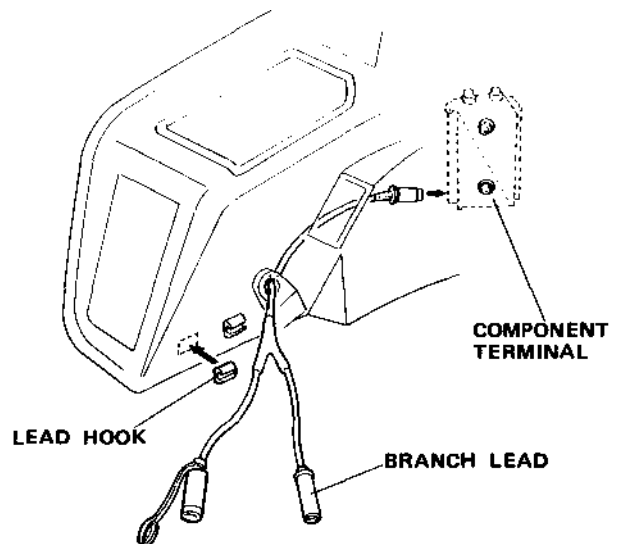

CB Controller Installation (Fig. 20)

Remove CB controller blind lid from controller holder and slide CB controller into controller holder and install using four socket bolts.

Fig. 20

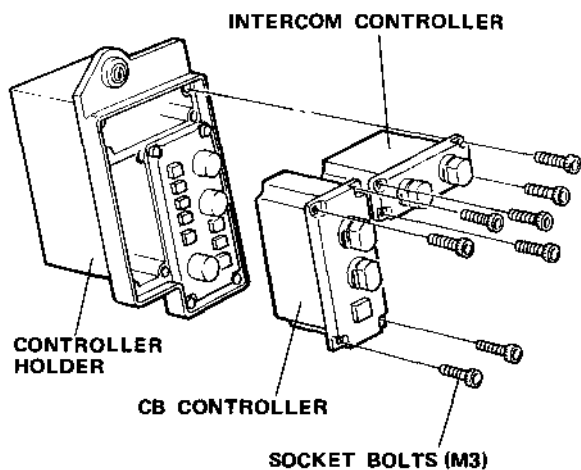

Connector Plugging in (Fig. 23)

Plug in all connectors should be connect to component terminal as shown.

Fig. 23

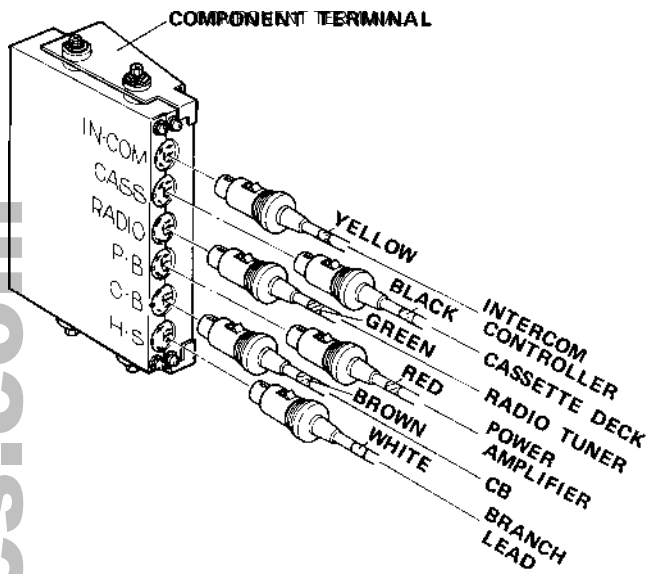

Routing Wires Inside Fairing (Fig. 24, 25)

- 1) Bundle all harness wires passed out of left turn signal lens hole (not yet connected) with ties (1) and (2) ((a) in Fig. INT-6).
- 2) Connect Inter corn wires and other wires ((b) in Fig. INT-6).
- 3) Connect audio main harness to sub harness G, fairing wire and other wires ((c) in Fig. INT-6).
- 4) Bundle wires and harness with ties as shown ((d) in Fig. INT-6).

Fig. 24

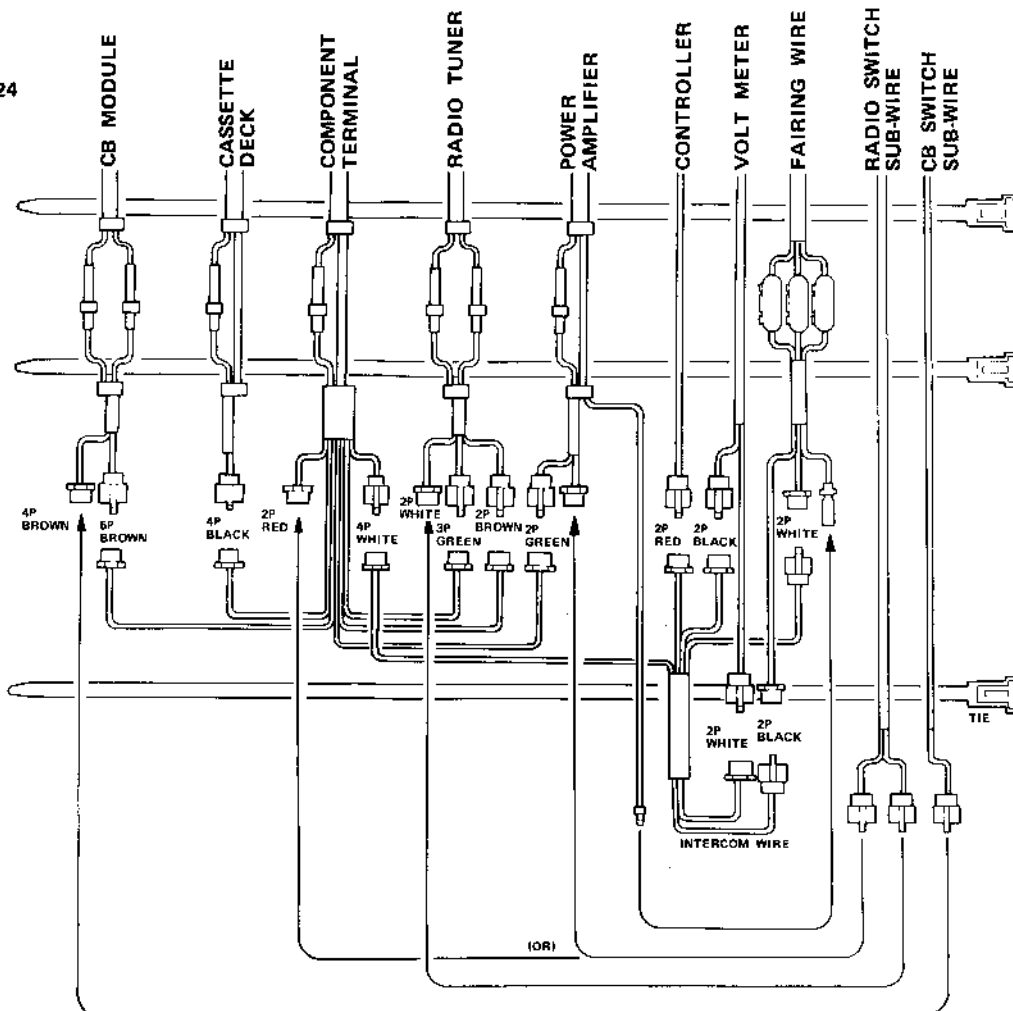

- 5) Press all bundled wires and harness into fairing through left turn signal lens hole.

Fig. 25

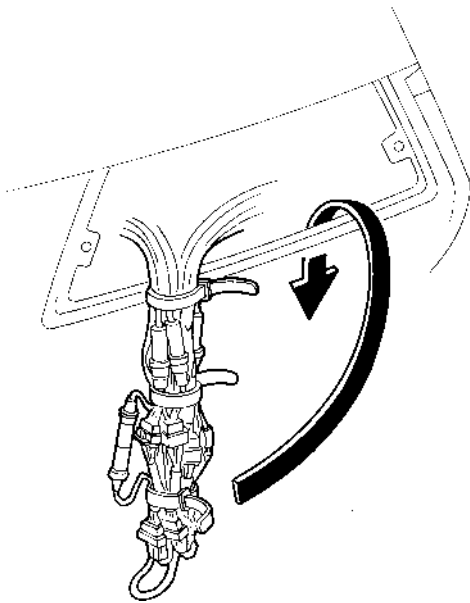

Cassette Deck Installation (Fig. 26, 27)

- 1) Install front and rear cassette deck nut plates as shown.
- 2) Install Cassette deck base.

Fig. 26

4 SEMS HEX BOLTS (M4)

CASSETTE DECK BASE

SEMS SCREWS (M3)

TO COMPONENT TERMINAL

CASSETTE DECK FRONT NUTPLATE

CASSETTE DECK REAR NUTPLATE

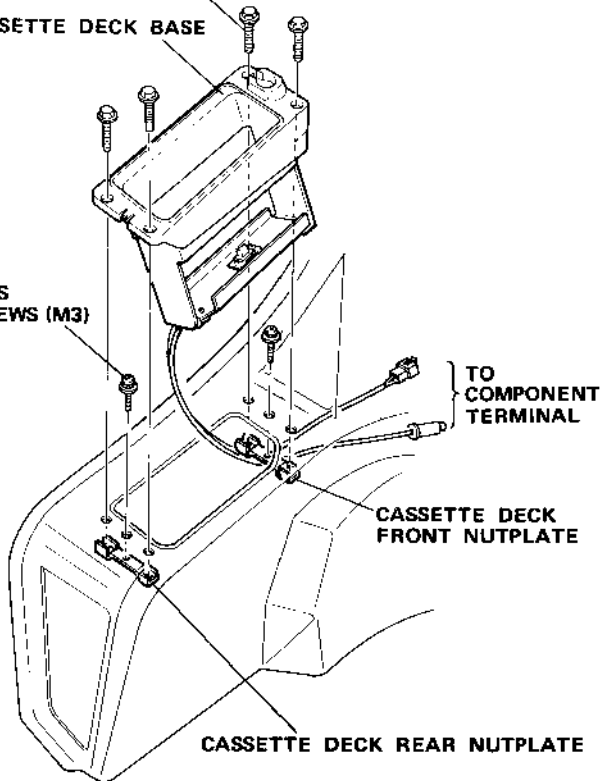

- 3) Route wire through left turn signal lens hole and secure wire temporarily.
- 4) Set cassette deck in deck base.

Fig. 27

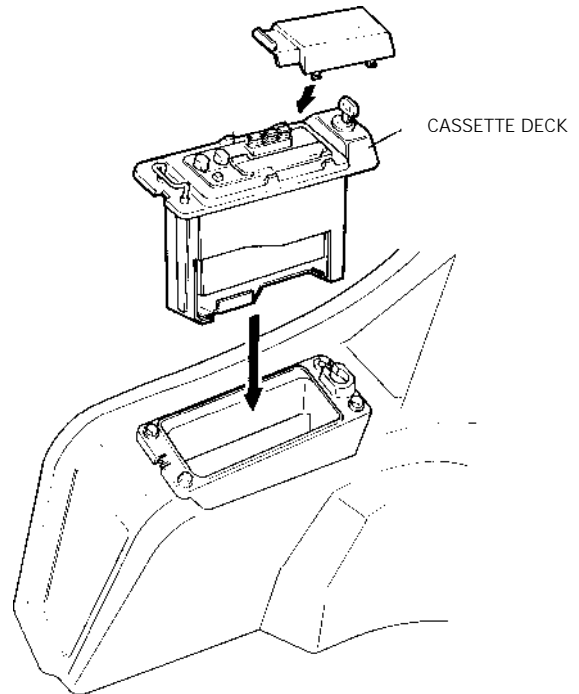

CB Switch Installation (Fig. 28, 29, 30, 31)

- 1) Install CB switch and Radio switch as shown.

Fig. 28

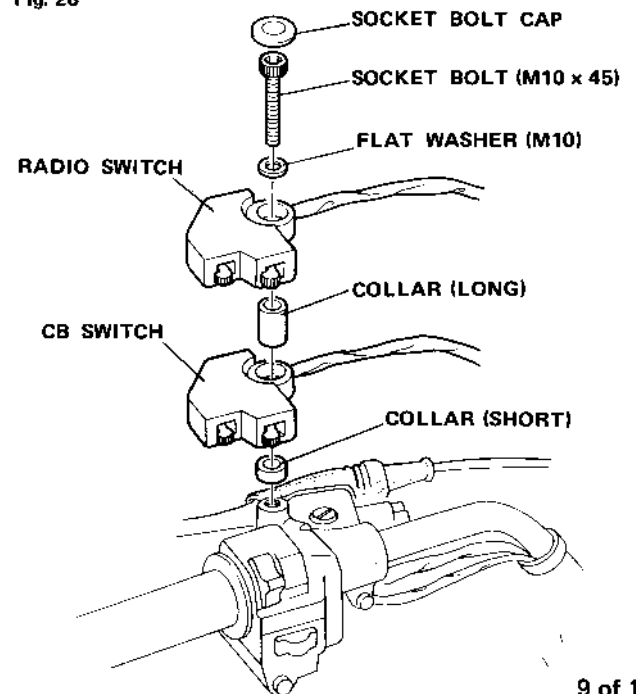

- 2) Route switch wire along with turn signal switch wires and radio switch wire and attach them to handlebar with wire bands positioned where shown.

Fig. 29

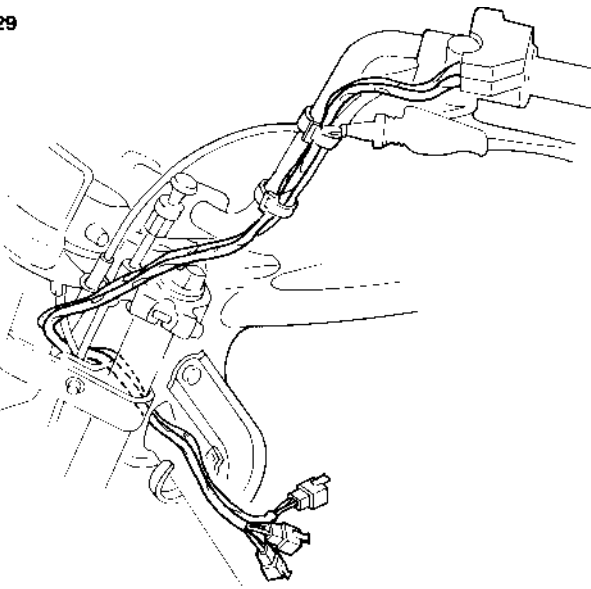

- 3) Install CB passenger switch on rear luggage as shown.

Fig. 30

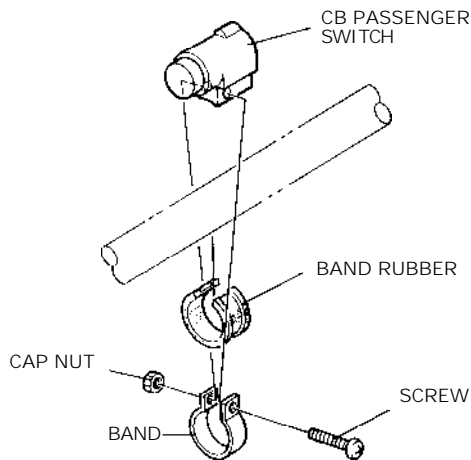

- 4) Route CB passenger switch sub wire along with antenna feeder.

Fig. 31

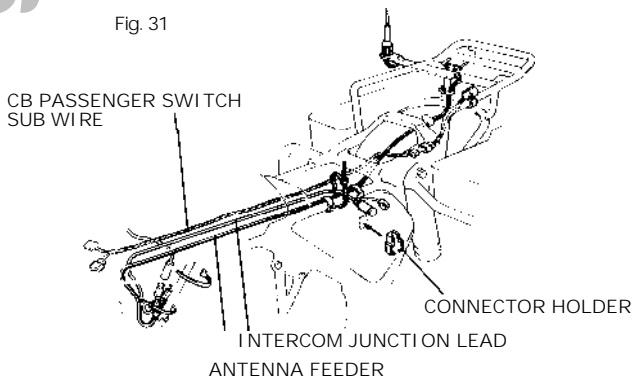

Securing Junction Lead (Fig. 31)

- 1) Route the junction lead along the antenna feeder and secure with plastic tie where shown.
- 2) Attach connector holder to left side cover, and insert passenger's Din connector in holder.

FAIRING INSTALLATION (Fig. 32)

- 1) Install fairing on motorcycle.
- 2) Connect motorcycle wire 9-P connector and ground wire to fairing connector and ground connection. Place connector cover over connections.
- 3) Connect radio switch wires to switch sub-harness wires.
- 4) Connect CB switch wires and CB passenger switch sub wires to CB switch sub harness wires.
- 5) Connect antenna feeder to feeder from distributor.
- 6) Connect branch lead to junction lead and attach it and antenna feeder to fairing mount flame with wire band.

Fig. 32

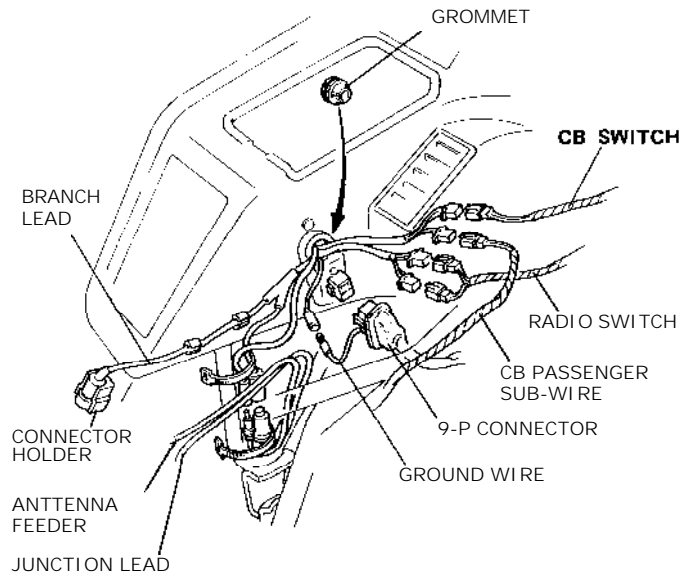

WIRE ROUTING AND FUSES (Fig. 33)

1) Connect all wires to wire harness terminals properly.

2) Fuses are located in left turn signal base. To replace fuses, remove left turn signal.

Fig. 33

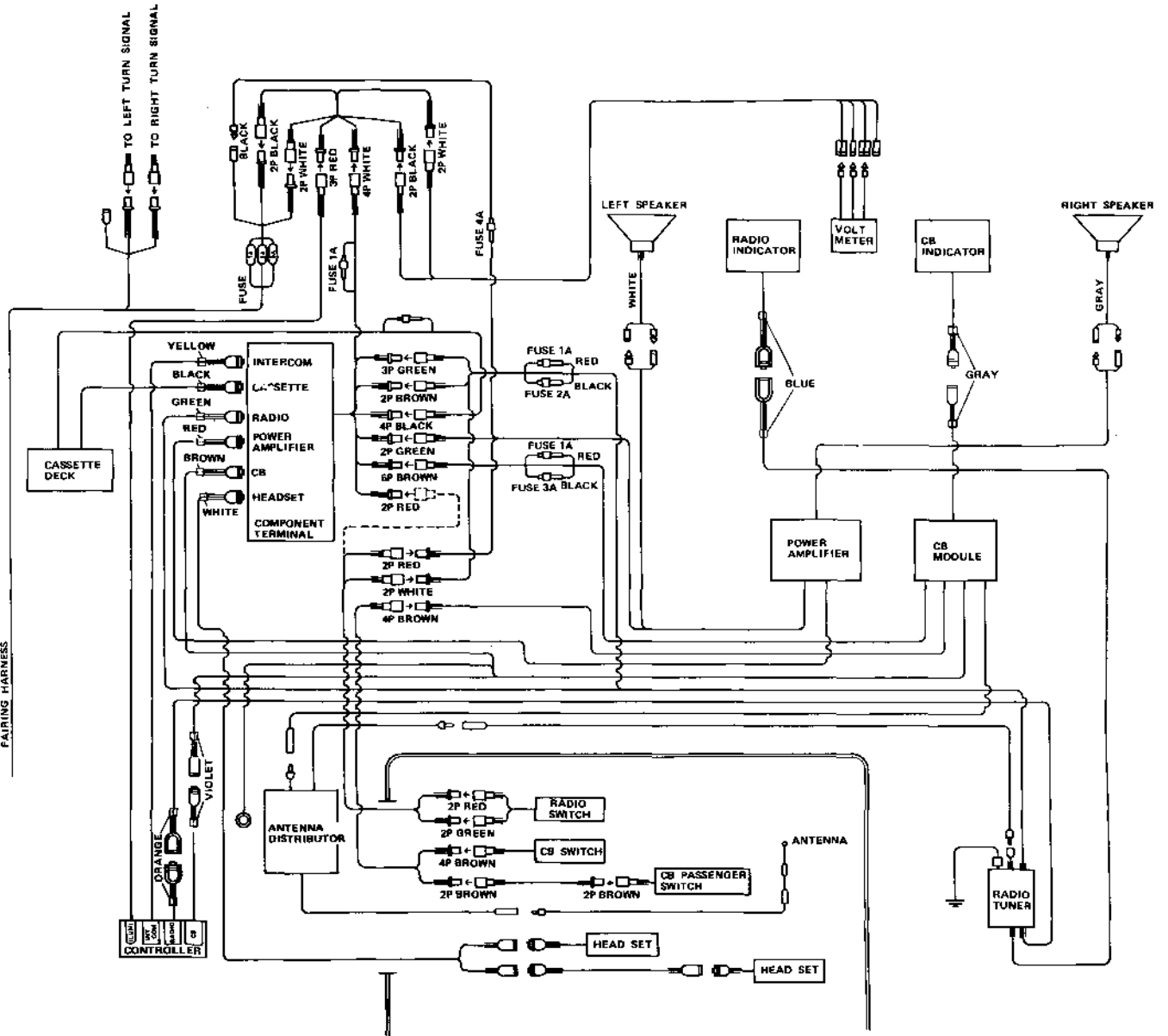

goldwingdocs.com

TOOLS REQUIRED

- # 1 and # 2 Phillips screwdrivers
- 8mm Box wrench
- 2.5mm Allen wrench

PARTS LIST(Fig.1)

Fig. 1

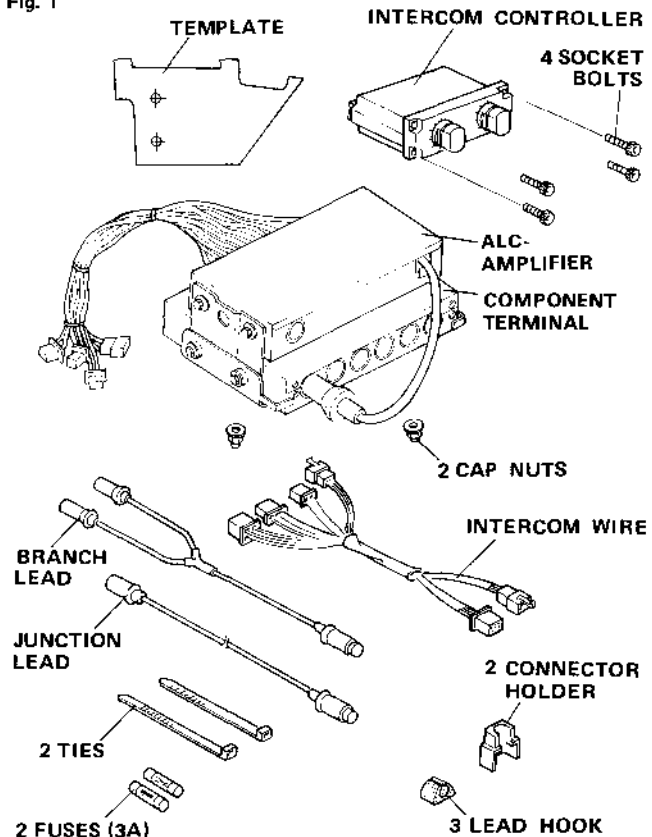
**REWORKING****Remove Fairing Parts (Fig. 2)**

Remove left fairing pocket and left turn signal lense.

Fig. 2

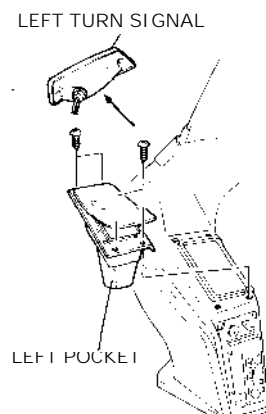
**Reworking on fairing (Fig. 3,4)**

- 1) Lightly roll template so that it will follow contour of fairing snugly.
- 2) Position template on fairing with its upper and outer edges aligned with those of fairing as indicated by arrows.
- 3) Attach template to fairing using adhesive tape where shown.
- 4) Punch mark centers of two holes with a drift and hammer.
- 5) Drill 6 mm holes through marked centers.

Fig. 3

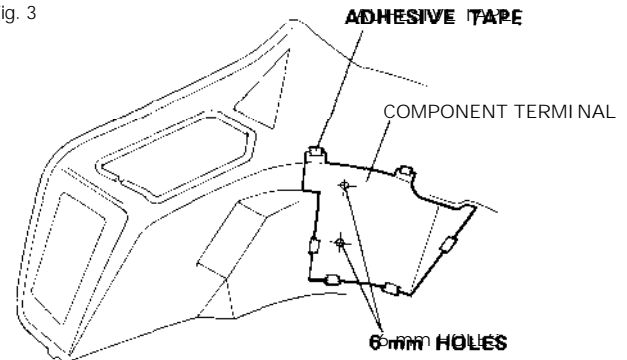

- 6) Install six wire clips to temporarily secure wires as shown.

Fig. 4

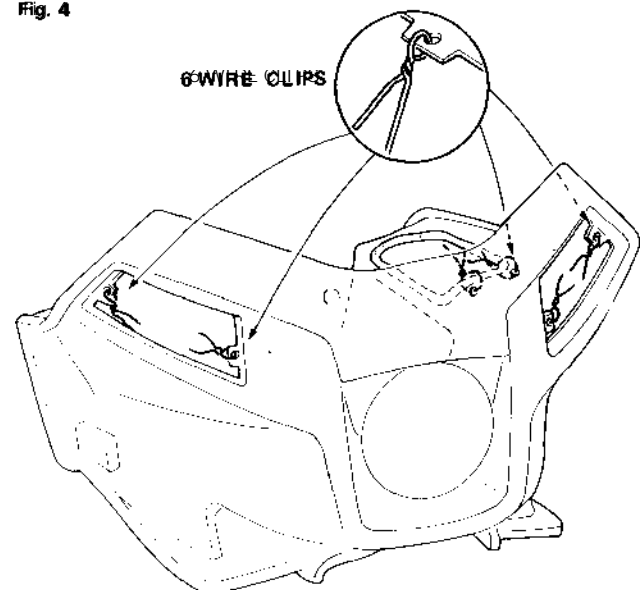

- 7) Install windshield on fairing before installing speakers.

Removing Radio Parts (Fig. 5, 6, 7)

Remove several radio parts from fairing as follows when already radio mounted.

- 1) Pull out bundled wires through left turn signal lens hole.

Fig. 5

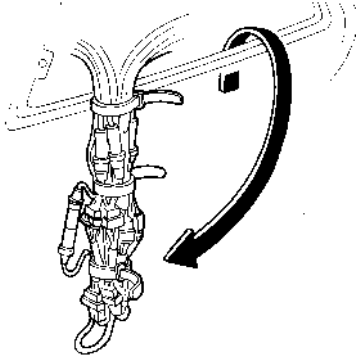

- 2) Unbundle three ties and disconnect adapter wire harness and RADIO/PA JOINT WIRE.

Fig. 6

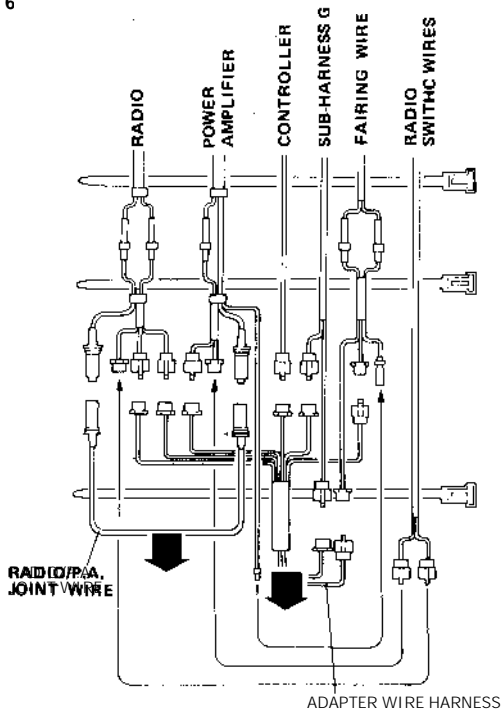

- 3) Disconnect and remove one antenna feeder of two.

Fig. 7

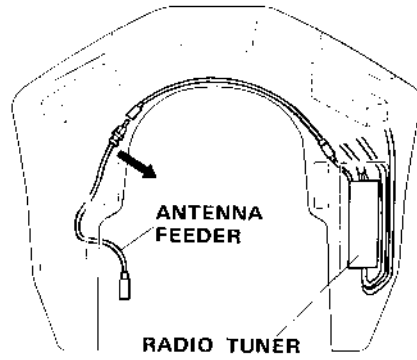

INSTALLATION ON FAIRING

Component Terminal and ALC-Amplifier Installation (Fig. 8)

- 1) Insert component terminal into fairing through left pocket hole.
- 2) Insert component terminal studs into holes in fairing and install using a cap nut on each stud. Tighten securely.
- 3) Pull out wires through left turn signal lens hole and secure with wire clip.

Fig. 8

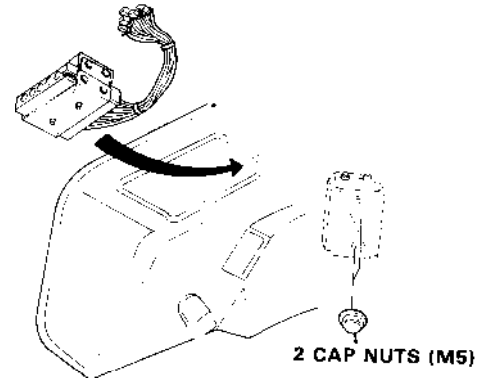

Branch Lead Installation (Fig. 9)

- 1) Pass branch lead in through hole above 9-pin connector and plug in to ALC-Amplifier.
- 2) Attach lead hooks and secure branch lead with them where shown.

Fig. 9

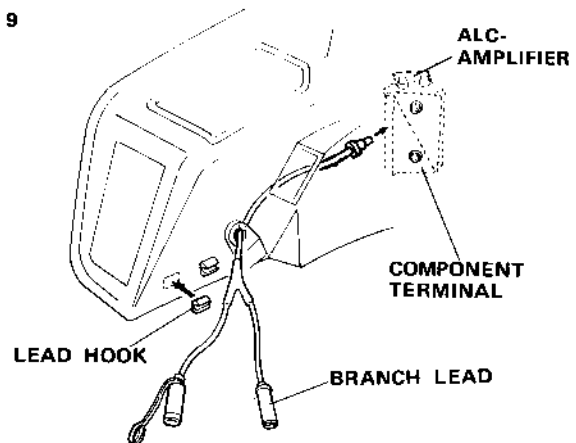

Connector Plugging in (Fig. 10)

Plug in all connectors should be connect to component terminal as shown.

Fig. 10

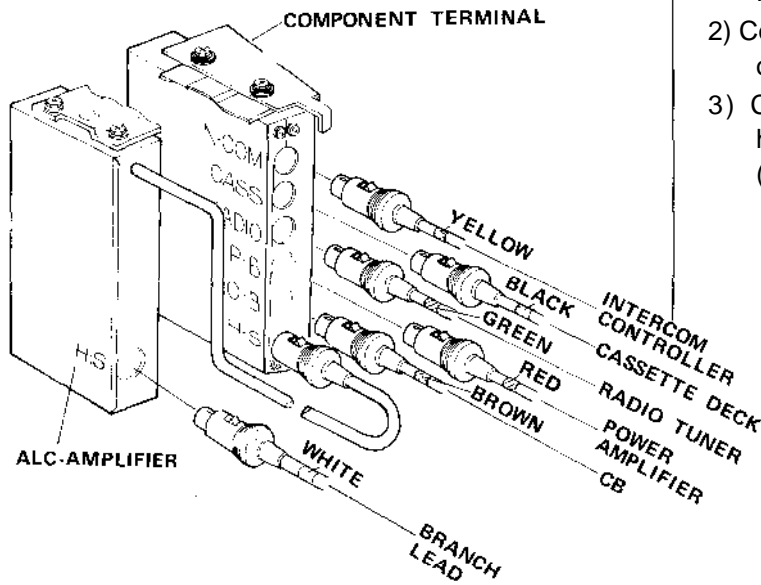

Routing Wires Inside Fairing (Fig.11, 12)

- 1) Bundle all harness wires passed out of left turn signal lens hole (not yet connected) with ties (1) and (2) ((a) in Fig. 11).
- 2) Connect COMPONENT TERMINAL wires and other wires ((b) in Fig. 11).
- 3) Connect audio main harness to sub harness G, fairing wire and other wires ((c) in Fig. 11).

Fig. 11

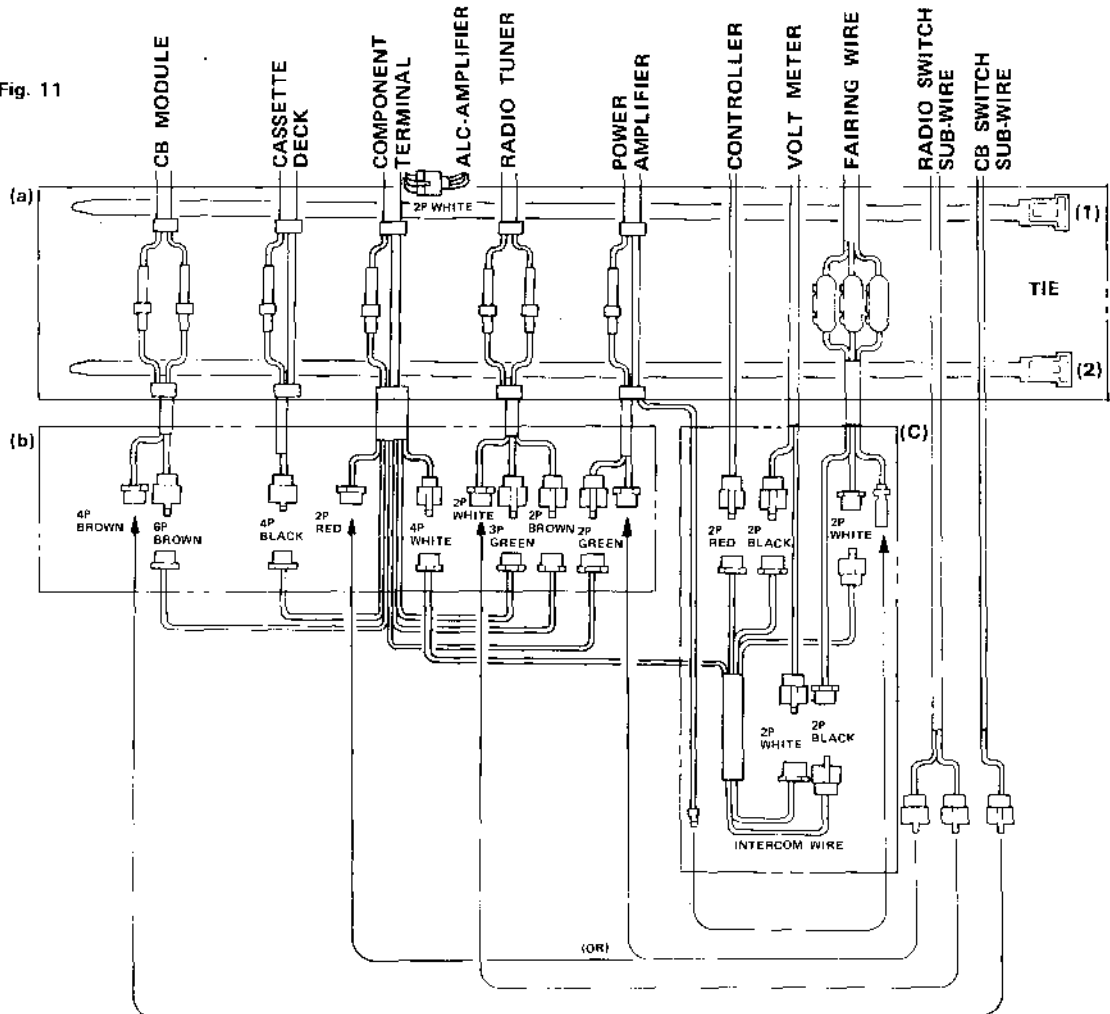

- 4) Press all bundled wires and harness into fairing through left turn signal lens hole.

Fig. 12

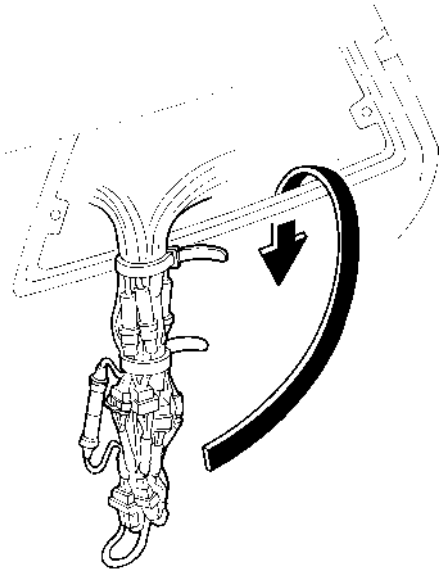

INTERCOM Controller Installation (Fig. 13)

Remove INTERCOM controller blind lid from controller holder and slide INTERCOM controller into controller holder and install using four socket bolts.

Fig. 13

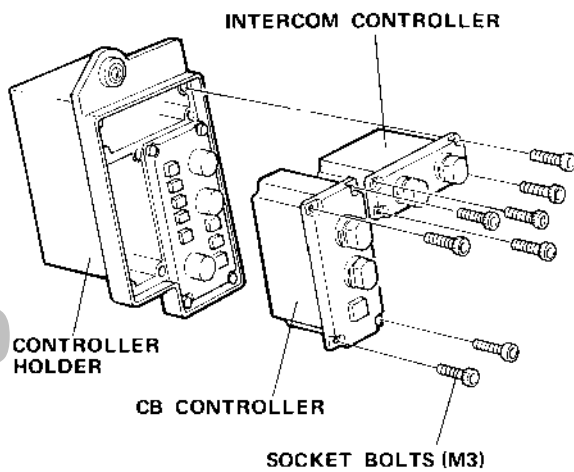

■ **Dépose des pièces radio (fig. 5, 6 et 7)**

Déposer les diverses pièces radio du carénage en procédant comme suit dans le cas où la radio est déjà montée.

- 1) Sortir la botte de fils par le trou du diffuseur de clignotant gauche.

Fig. 5

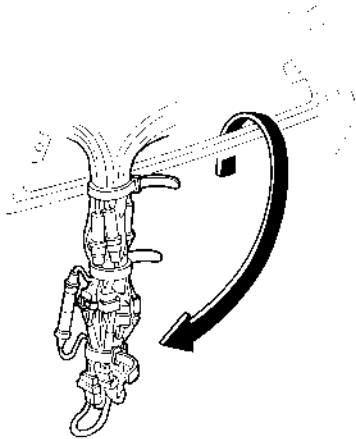

- 2) Défaire les trois attaches et déconnecter le faisceau de fils de l'adaptateur et le FIL RADIO/AMPLIFICATEUR DE PUISSANCE.

Fig. 6

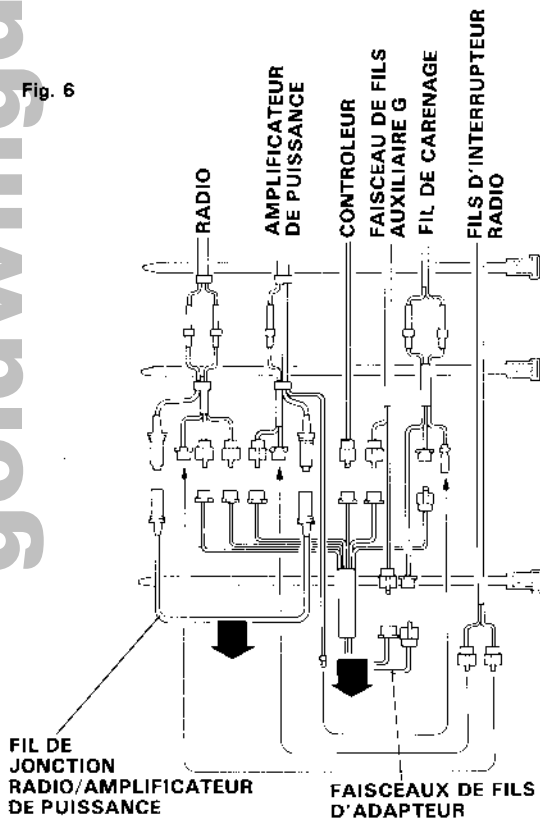

- 3) Déconnecter et déposer un feeder d'antenne sur deux.

Fig. 7

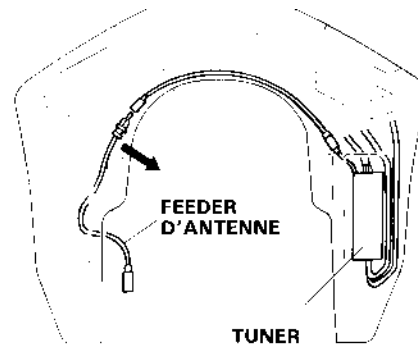

POSE SUR LE CARENAGE

■ **Pose de l'unité de bornes de raccordement et l'ALC-amplificateur. (fig. 8)**

- 1) Introduire l'unité de bornes de raccordement dans le carénage à travers l'orifice du diffuseur de clignotant gauche.
- 2) Introduire les goujons de l'unité dans les orifices du carénage et les poser à l'aide d'un écrou borgne pour chacun. Serrer à fond.
- 3) Sortir les fils par l'orifice du diffuseur de clignotant gauche et les fixer avec un attache-fils.

Fig. 8

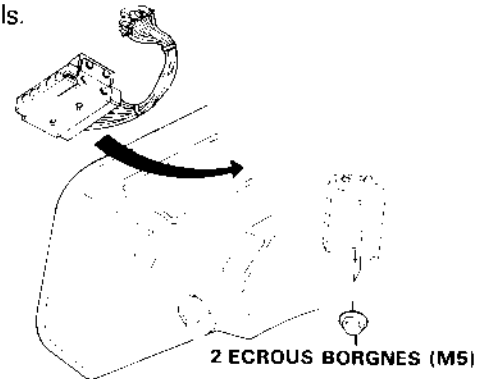

■ **Pose du câble de dérivation (fig. 9)**

- 1) Introduire le câble de dérivation à travers l'orifice se trouvant au-dessus du connecteur à 9 broches et le brancher dans l'ALC-Amplificateur.
- 2) Fixer les crochets de câble et assujettir le câble avec eux aux endroits indiqués.

Fig. 9

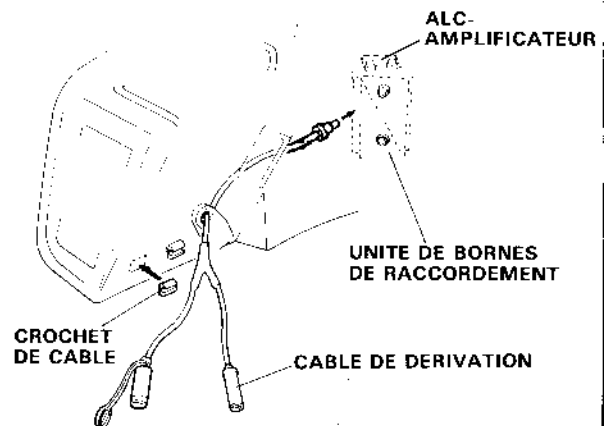

■ Branchement des connecteurs (fig. 10)

Les connecteurs enfichables doivent être branchés dans l'unité de bornes de raccordement comme le représente la figure.

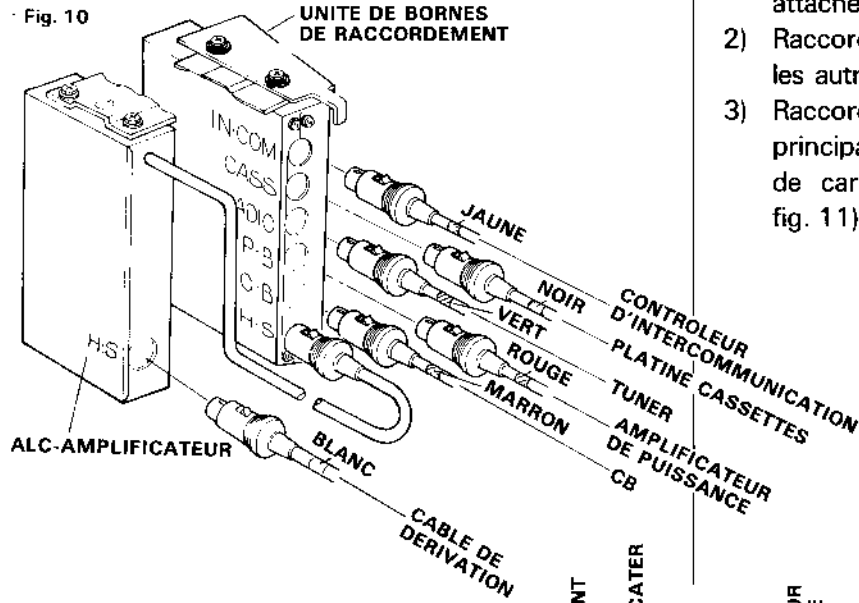

■ Cheminement des fils à l'intérieur du carénage (fig. 11 et 12)

- 1) Attacher tous les fils de faisceau sortant de l'orifice du diffuseur de clignotant gauche (non encore connectés) avec les attaches (1) et (2) ((a) à la fig. 11).
- 2) Raccorder les fils d'intercommunication et les autres fils ((b) à la fig. 11).
- 3) Raccorder le faisceau de fils audio principal au faisceau auxiliaire G, au fil de carénage et aux autres fils ((c) à la fig. 11).

Fig. 11

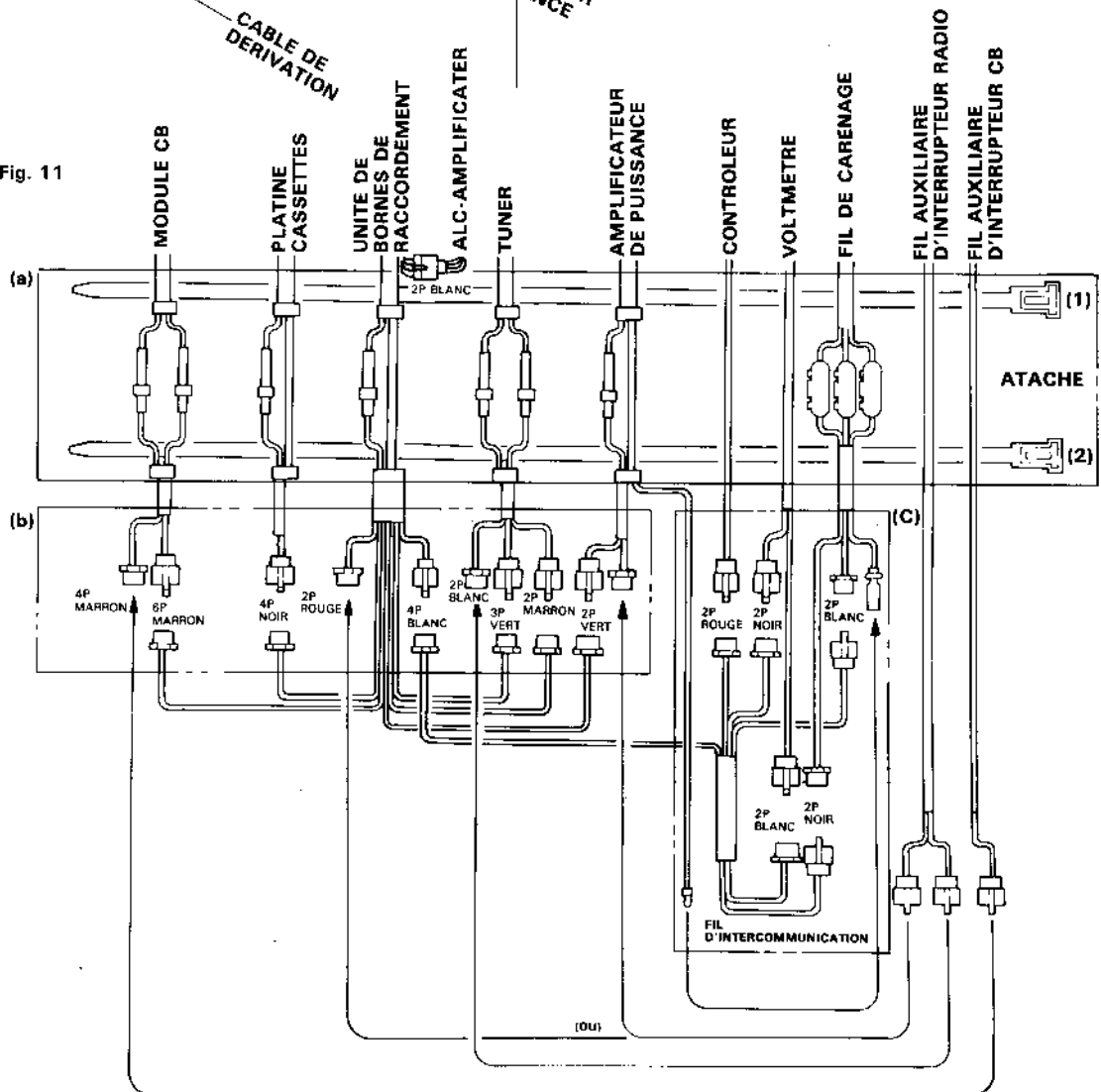

- 4) Pousser tous les fils et faisceaux attachés dans le carénage par l'orifice du diffuseur de clignotant gauche.

Fig. 12

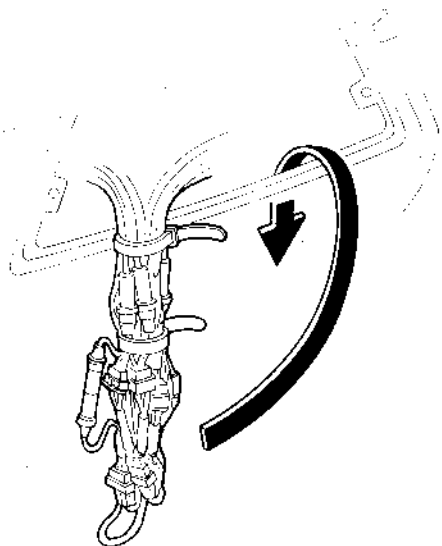

■ **Pose du contrôleur d'intercommunication (fig. 13)**

Déposer le cache de contrôleur d'intercommunication se trouvant sur le porte-contrôleur et glisser le contrôleur d'intercommunication dans le porte-contrôleur. Le poser à l'aide de quatre boulons hexacaves.

Fig. 13

